

# TRITORC

B O L T O N T R U S T



TRITORC

**BOLTING  
& HYDRAULIC  
& TOOLS**

# TRITORC - THE BOLTING EXPERT

A largely manufacturing based firm that we are, we constantly gear towards engineering the finest products available.

TRITORC products are calibrated and certified at an in-house calibration facility that ensures torque testing the final products. Our R&D experts provide constant input with which we design some of the extensively used tools in the service industry. The repair team deserves praise when it comes to tackling maintenance issues making it easy for the customer. TRITORC products are known for the superior quality, durability, robustness and flawless finish - **"We bring Perfection and Innovation to the next level."**

Currently serving USA, Europe, Africa, Middle East, and Southeast Asia, we are keen at extending the reach...

## INDUSTRY SECTORS THAT WE SERVE:

- Petrochemicals and Refineries
- Oil Exploration
- Power Stations
- Wind Power
- Chemical Industries
- Mines & more

TRITORC has been extensively involved in the Service industry. Some of the major contribution is in the Oil and Gas sector serving the Petroleum industry spread across Middle East, West Africa and India. This is why we believe that **"Service is in our DNA."**

As a service driven organization, we value ourselves for our proactive nature of conduct. TRITORC Experts on-site are swift at taking decisions and the work force is always on their toes when it comes to attending to problems. With an adequate work force of skilled workers and experienced engineers, and a line of certified & calibrated tools, we offer 24x7 services.

## TRITORC Bolting Services offer:

- 1) Flange management system
- 2) Pre-Commissioning and Start up Service
- 3) Asset Management
- 4) Onsite & Offsite Bolting Services
- 5) Bolting Software
- 6) Cold Cutting

Backed by a team of experts that is proficient in various technical, management and customer service areas, TRITORC raises the bar in both Sales & Service industries.

*TRITORC also provides Rental Fleets that are provisioned with the equipments, engineers and workforce needed to support a project. This is an added facility that works hand in hand with the Partner to Progress program.*

**"Bolting is a passion at TRITORC"**



## PARTNER TO PROGRESS

TRITORC Partner to Progress is a program initiated to support Entrepreneurs in the Sales & Service industry. We at TRITORC welcome organizations from around the globe to PARTNER with us and as Pioneers, TRITORC would lead the way for new Business opportunities.

*Options available for becoming PARTNERS with TRITORC...*

### DEALER - PRINCIPAL RELATIONSHIP:

TRITORC introduces one of the conventional and globally accepted methods of Partnership, "Dealer - Principal Relationship". As TRITORC is always welcoming new Partners from any and all parts of the world to join hands in a Long Term relationship, "Dealer - Principal Relationship" is the ideal program.

- In this program the PARTNER receives a special Discount structure.
- TRITORC will assist in Sales operations and Tender execution as and when necessary.
- The Dealership is exclusive to the Region, and our sales executive will assist in joint visits as a token of support.

### COST & REVENUE SHARE:

TRITORC is extensively involved in the Service Industry...

*"TRITORC Allocates, Aids, and Advocates the Service Industry."*

Equal Cost & Revenue Share is a program that has the sole purpose of supporting the Entrepreneurs in the Service Industry.

In this program TRITORC supplies and invests on tools & equipments. We provide an experienced Operations Manager & Sales Manager to execute and develop new prospects.

- In this Program TRITORC invests on the Rental Fleet.
- PARTNER must provide space for safekeeping of the Tools & Manpower.
- PARTNER must provide VISA, Accommodation and work area for TRITORC Operation Manager & Sales Manager.
- Also they must allocate Man-Power for the Project and bear expenses for the same.

### JOINT VENTURE:

TRITORC Joint Venture is a program that brings the Local organization and TRITORC together where both organizations co-actively participate, become co-beneficiaries, and co-operate in executing the project.

This is a very transparent program where both partners are equally involved in the project. Here the Partners face a win - win situation with relation to cost & revenue sharing. Ideally when TRITORC Cost & Revenue partnership matures - it becomes Joint Venture partnership...

# Content

Hydraulic Torque Wrench Square Drive Type	1
Hydraulic Torque Wrench Hex Type	4
Heavy Duty Impact Socket	8
Slugging/ Striking Wrenches	9
Hexagon Reducer Bushes	10
Electric Powerpack - Automatic	12
Air Operated Powerpack	13
Atex Pump - Electric / Pneumatic	13
Electric Shear Wrench	14
Electric Torque Wrench	15
Manual Torque Wrench	16
Electric Torque Multiplier	18
Pneumatic Impact Wrenches	19
Top-side Bolt Tensioner	20
Spring Return Tensioner	21
Multi-Stage Hydraulic Tensioner	22
Sub-Sea Hydraulic Bolt Tensioner	23
Ultra High Pressure Pump	24
Air Power Pack for Bolt Tensioner	25
Hand Pumps for Bolt Tensioners	25
Nut Splitter	26
Flange Spreader	28
Non Sparking Tools	30
Powerpack/ Handpump for Cylinders	32
Hydraulic Cylinders	33



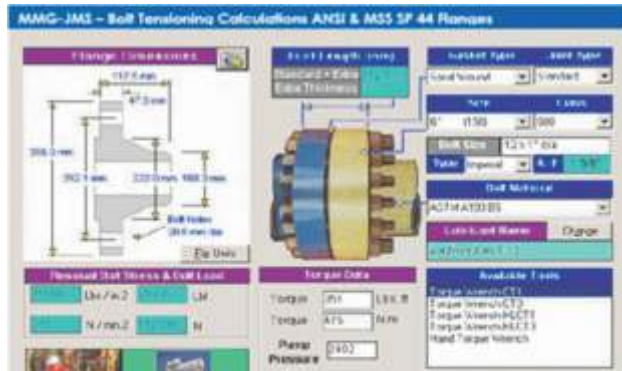

FLANGE MANAGEMENT SYSTEM



OFFSHORE BOLTING SERVICES



ACCURATE TENSIONING SERVICES



CALIBRATION SERVICES



COLD CUTTING



ULTRASONIC LOAD TESTING



24 x 7 SUPPORT

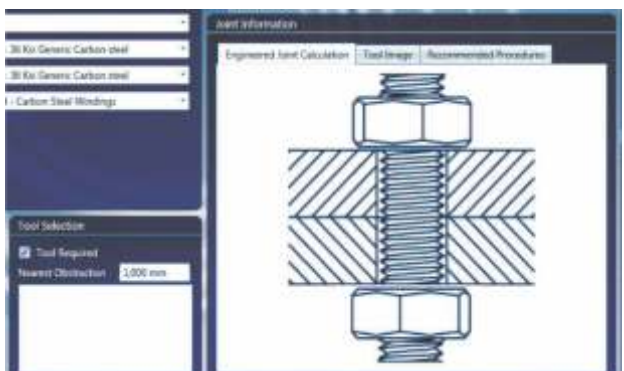

BOLTING SOFTWARE

# TSL SERIES SQUARE DRIVE TORQUE WRENCHES

**ANNOTATION:**

- 1) Quick push through drive for ease of loosening and tightening
- 2) Fine Ratchet and Pawl for better engagement
- 3) Multi tooth drive segment ensures upto 32°
- 4) Balance drive Rod - Side load & free piston movement
- 5) Laser engraved torque chart (Nm & ft lbs)
- 6) Hard chrome plating of piston rod which ensures better wear resistance of rod seal.
- 7) Self lubricating low Nickel Bronze drive bush to protect body from wear
- 8) 360°x180° swivel for better degree of movement
- 9) Leak proof quick connect couplers for easy & safe operation
- 10) End-cap design for sufficient back pressure for smooth piston forward force
- 11) Rigid reaction suitable for heavy load application
- 12) Simple design reaction arm release button for ease of operations
- 13) Alloy Steel reaction boot (Available in multi-color option)
- 14) Cold worked cylinder bore for longer life and super finish for long working conditions.

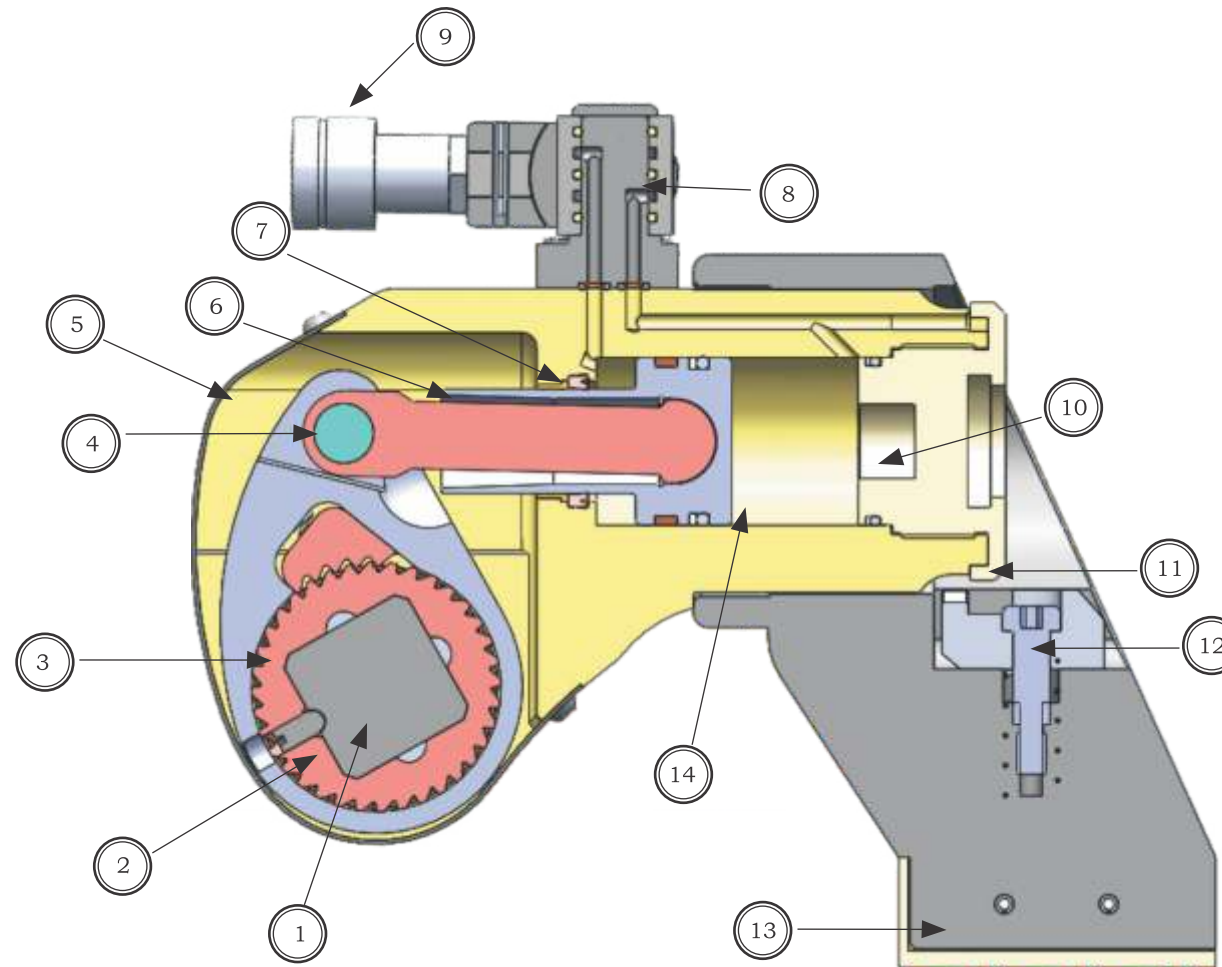

TRITORC manufactures Simple, faster, efficient and reliable Hydraulic Torque Wrenches that are user friendly. The high strength alloy steel and controlled vacuum heat treatment ensures stronger drive components. Improved high pressure seal design is suitable for static & dynamic applications.

**There are -**

- Provision for lifting tools/ handle.
- Standard spline design with torque effective length for exact PCD engagement of reaction Arm.
- High strength aerospace aluminum material for light weight and stronger body design.
- Scratch proof hard anodized body and reaction arm.

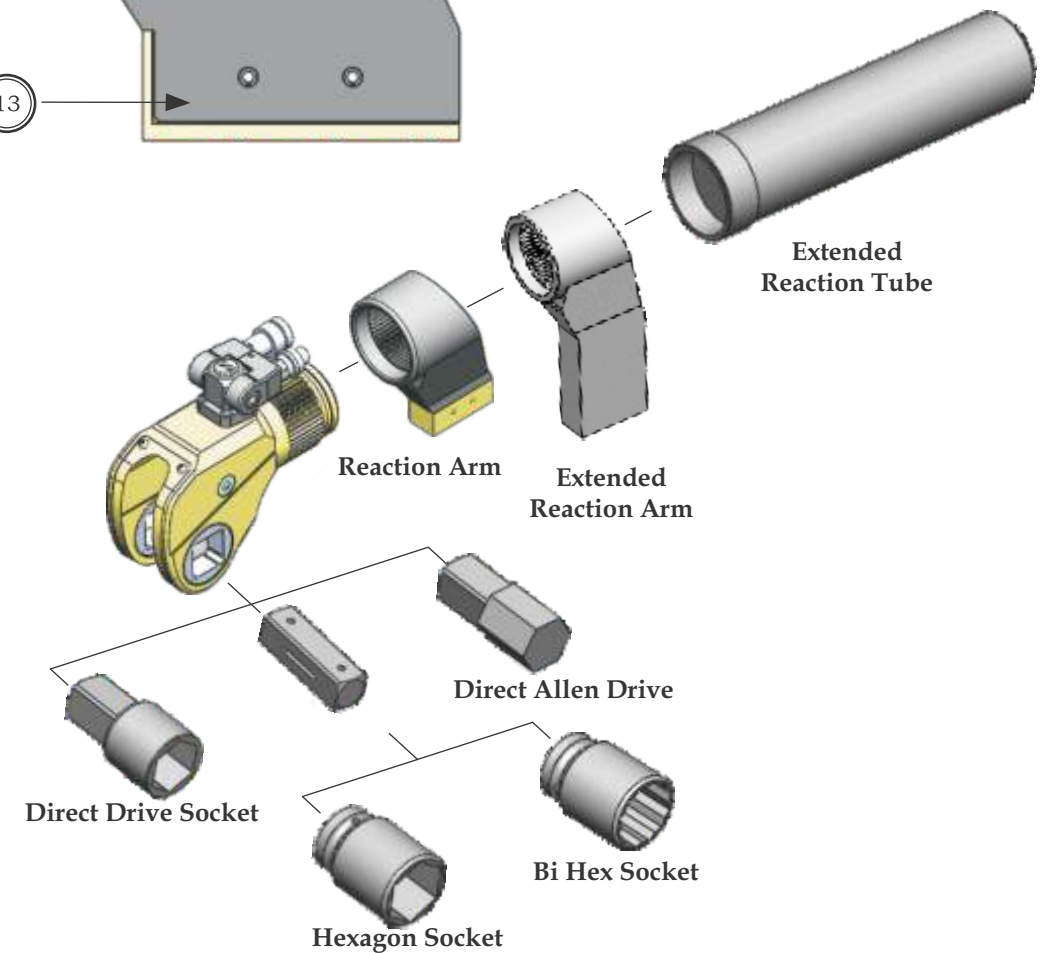

TRITORC RECOMMENDS USE OF TRITORC STANDARD ACCESSORIES ENSURING PRECISE PERFORMANCE & BEST SUITABILITY



# TSL SERIES SQUARE DRIVE TORQUE WRENCHES

## TECHNICAL DATA

TECHNICAL DATA	Units	TSL-07	TSL-1	TSL-3	TSL-5	TSL-8	TSL-10	TSL-20	TSL-25	TSL-35	TSL-50
Square Drive	Inch	3/4	3/4	1	1. 1/2	1. 1/2	1. 1/2	2. 1/2	2. 1/2	2. 1/2	2. 1/2
Min. Torque	Nm	108	180	450	750	1050	1533	2600	3460	4860	6925
Max. Torque	Nm	1130	1840	4520	7530	10800	15330	26675	34750	48675	69247
Min. Torque	Ft. Lbs.	80	135	331	553	775	1131	1917	2551	3611	5107
Max. Torque	Ft. Lbs.	830	1357	3333	5553	7965	11307	19675	25630	36113	51073
Tool Weight	Kg.	1.8	2.5	4.9	9.5	10.8	14.7	26	34.8	50	65
Tool Weight	Lbs.	3.9	5.5	10.8	20.9	23.7	32.4	57.2	74.8	110	143

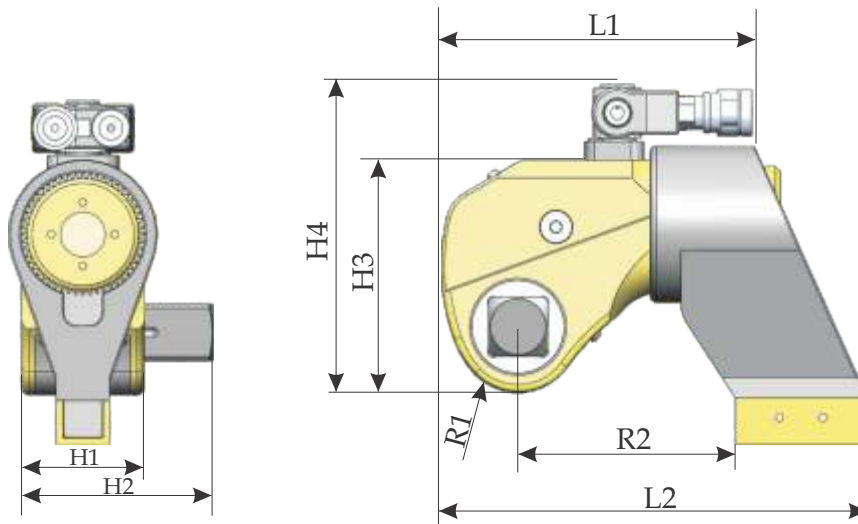

## DIMENSIONAL DATA

DIMENSIONAL DATA	Units	TSL-07	TSL-1	TSL-3	TSL-5	TSL-8	TSL-10	TSL-20	TSL-25	TSL-35	TSL-50
Body Length (L1)	(mm)	110	144.5	178	213	222	246	305	321	371	376
	(Inch)	4.33	5.69	7.0	8.38	8.74	9.69	12	25.68	14.6	14.8
Overall Length (L2)	(mm)	139	173	228	274.5	292	317	383	401	465	528
	(Inch)	5.47	6.81	8.98	10.80	11.49	12.48	30.64	15.78	18.3	30
Tool Width (H1)	(mm)	42	52	69.5	82.5	92	102	121.5	120	137	162
	(Inch)	1.65	2.04	2.74	3.24	3.14	4.01	3.93	4.72	5.39	6.14
Overall Width (H2)	(mm)	65	70	94	128.5	134	142	183	200	216	226
	(Inch)	2.55	2.76	3.7	5.06	5.2	5.59	7.2	7.87	8.5	8.9
Tool Height (H3)	(mm)	77	95.5	115	149	167	182	220	246	282	291
	(Inch)	3.03	3.76	4.53	5.87	6.57	7.16	8.33	9.68	11.1	11.5
Overall Height (H4)	(mm)	108	136	176	199	217	232	270	297	332	326
	(Inch)	4.25	5.35	6.93	7.83	8.54	9.13	10.62	11.69	13.07	12.83
Tool Radius Around Bolt (R1)	(mm)	21	26.3	34.5	39	47	51	59	66	77	78.8
	(Inch)	0.82	1.03	1.36	1.53	1.85	2	2.32	2.59	3.03	3.1
Reaction Reach (R2)	(mm)	68	85	111.5	140	153	154	186	199	241	295
	(Inch)	2.67	3.35	4.39	5.51	6.02	6.06	7.32	7.83	9.48	11.6

# THL-SERIES DIRECT HEX TYPE TORQUE WRENCHES

## TECHNICAL DATA

TECHNICAL DATA	Units	THL - 2		THL - 4		THL - 8		THL - 14	THL - 32	
		Min. Torque	Nm	230	240	575	640	1050	1160	1850
Max. Torque	Nm	2350	2420	5865	6480	10950	11780	18525	41890	44600
Min. Torque	Ft. Lbs.	180	176	400	474	777	860	1370	3038	3297
Max. Torque	Ft. Lbs.	1850	1784	4500	4800	8111	8726	13722	31030	33038
Across Flat	mm	19 - 55	55 - 60	34 - 65	70 - 80	41 - 95	100 - 105	50 - 117	110 - 155	160 - 175
	Inch	3/4 - 2.3/16	2.3/16 - 2.3/8	1.5/16 - 2.9/16	2.3/4 - 3.1/8	1.5/8 - 3.3/4	3.7/8 - 4.1/8	2 - 4.1/2	4.1/4 - 6.1/8	6.1/8 - 6.7/8
Weight	Kg.	1	1	2	2	3.3	3.3	5.5	11.4	11.4
Drive Unit	Lbs.	2.2	2.2	4.4	4.4	7.2	7.2	12.1	25.3	25.3
Weight	Kg.	1.6	1.7	4.4	4.6	8	8.4	11.6	29	30
Ratchet Unit	Lbs.	3.5	3.7	9.6	10.1	17.6	18.4	25.5	63.8	66

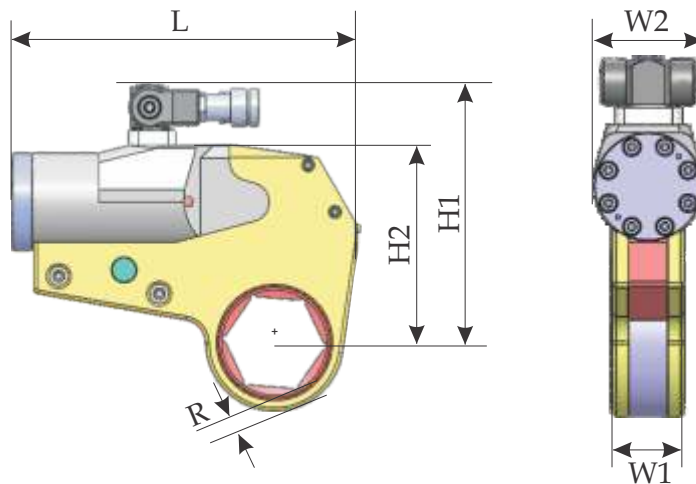

## DIMENSIONAL DATA

DIMENSIONAL DETAILS	Units	THL - 2		THL - 4		THL - 8		THL - 14	THL - 32	
		Overall Length (L)	(mm)	196	196	221	221	274	274	361
	(Inch)	7.7	7.7	8.7	8.7	10.79	10.79	14.27	16.92	17.36
(H1)	(mm)	125.9	128.5	171.3	171.3	206	206	239	303	315
	(Inch)	4.95	5.05	6.74	6.74	8.11	8.11	9.4	11.9	12.4
(H2)	(mm)	102.3	105	125	125	157	157	204	272	285
	(Inch)	4.02	4.13	4.92	4.92	6.18	6.18	8.03	10.7	11.22
Width at Link (W1)	(mm)	32	32	41.6	41.6	52.2	52.2	64	85	85
	(Inch)	1.25	1.25	1.64	1.64	2.055	2.055	2.55	3.34	3.34
Width at Cylinder (W2)	(mm)	51	51	63.5	63.5	78	78	99	131	131
	(Inch)	2	2	2.49	2.49	3.07	3.07	3.89	5.15	5.15
Nose Radius (R)	(mm)	27 - 43	43 - 46	36 - 53	56 - 61	46 - 71	75 - 78	60 - 87	85 - 155	160 - 175
R min.	(mm)	9.5	10.1	10.7	11.7	14.7	15.9	18.1	25.6	24.8
R max.	(mm)	12.2	10.5	13.8	14.6	15.2	18.7	20.7	31.3	27.3



# THL-SERIES DIRECT HEX TYPE

**ANNOTATION:**

- 1) Self-lubricating low Nickel Bronze for drive bush to protect body from wear.
- 2) Fine Ratchet & Pawl for better engagement.
- 3) Auto engagement of rod in first stroke
- 4) Slider prevents wear of piston and drive plate.
- 5) Leak proof quick connecting coupler.
- 6) 360°x180° swivel for better degree of movement.
- 7) Round shaped simple cylinder design
- 8) Hard chrome plating of piston rod for wear resistance
- 9) High quality German seals for high pressure design
- 10) Torsion free reaction pad.
- 11) Balanced load on side plate due to alignment pin
- 12) Cold worked cylinder bore for longer life and super-finish for long working condition
- 13) Never-Lock drive pawl

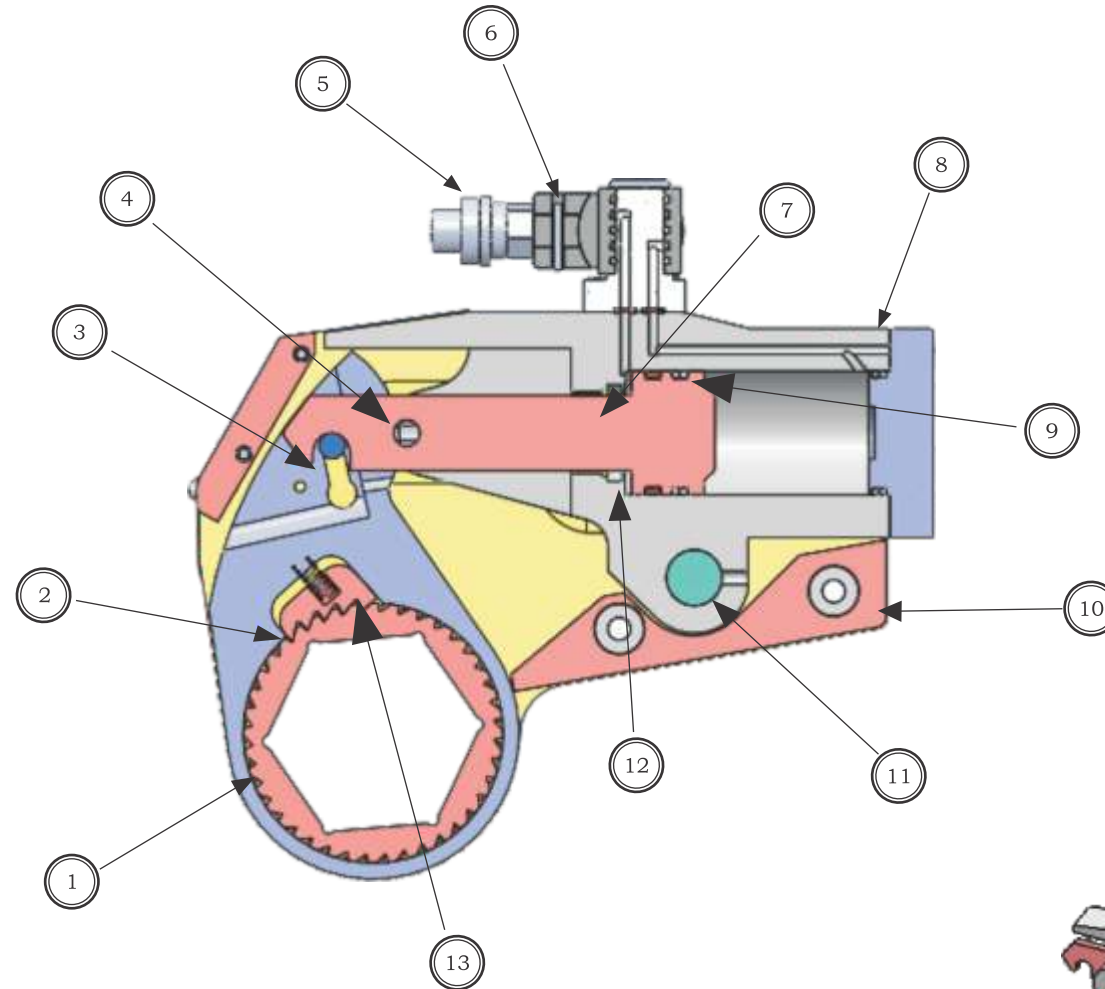

TRITORC THL-Series Direct Hex drive Hydraulic Torque Wrenches are designed for extreme low spaces where normal tools cannot reach. The light weight & compact hydraulic cylinder is made of special Aircraft grade Aluminum Alloy and the internal spares are made of high Nickel Alloy Steel. There are 5 models in THL series ranging from 230-45000 Nm. All models have small nose radius which allows the tool to fit in such areas where space constraint is observed.

## Accessories

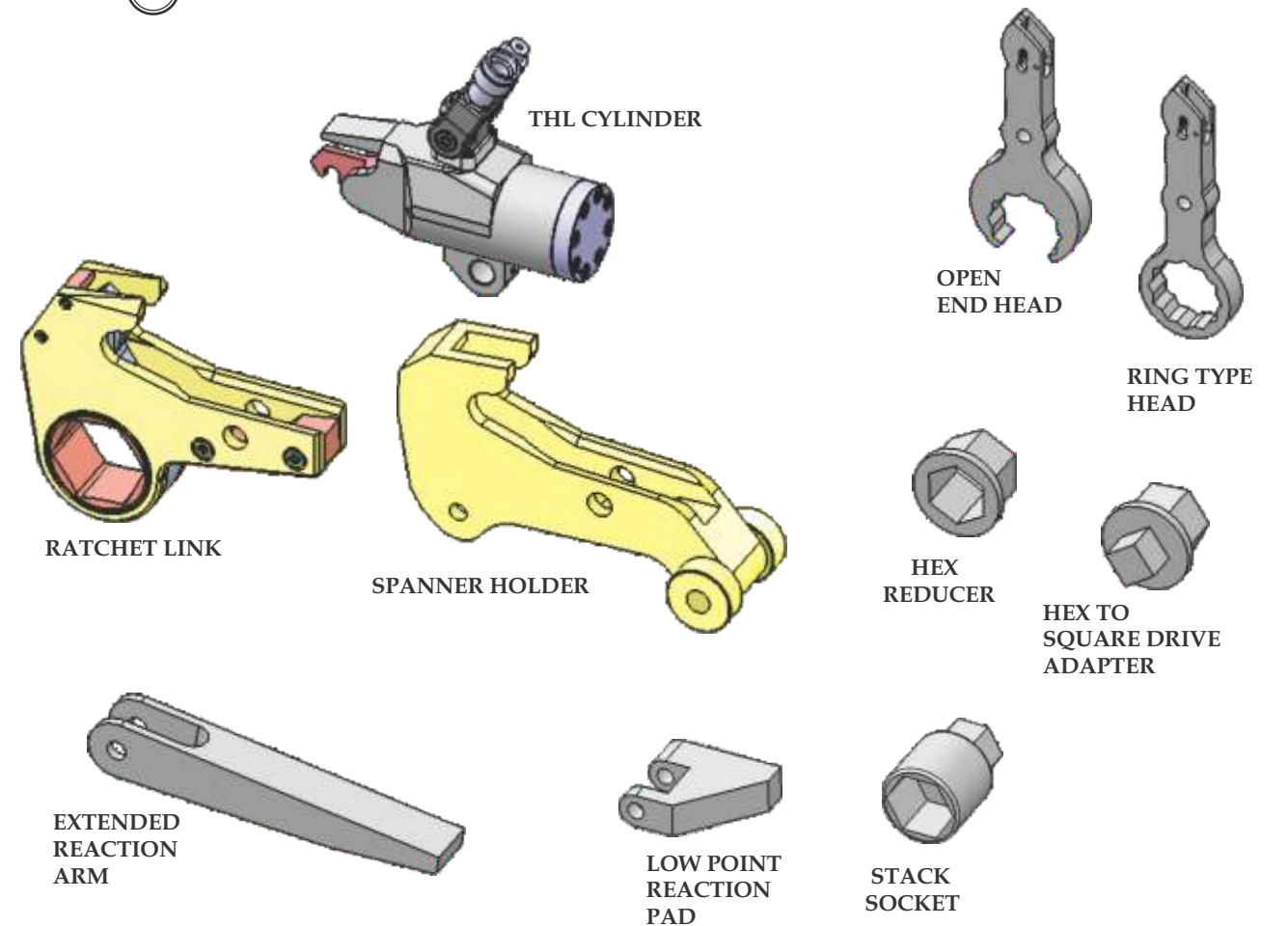

TRITORC RECOMMENDS USE OF TRITORC STANDARD ACCESSORIES ENSURING PRECISE PERFORMANCE & BEST SUITABILITY



## Features

- ▶ Compact design with longer arm improves the reliability.
- ▶ More accurate and easier to use, since the wrench directly operates on the nuts.
- ▶ 360x180 degree swivel or 360x360 degree swivel allows the wrench to operate freely in confined areas.

THL-2 Link	Hex Size	
	Imperial	Metric
HL-2-19	3/4"	19mm
HL-2-20	13/16"	-
HL-2-21	-	21mm
HL-2-22	7/8"	22mm
HL-2-23	15/16"	-
HL-2-24	-	24mm
HL-2-25	1"	-
HL-2-27	1-1/16"	27mm
HL-2-28	1-1/8"	-
HL-2-30	1-3/16"	30mm
HL-2-31	1-1/4"	-
HL-2-32	-	32mm
HL-2-33	1-5/16"	-
HL-2-34	-	34mm
HL-2-35	1-3/8"	35mm
HL-2-36	-	36mm
HL-2-37	1-7/16"	-
HL-2-38	1-1/2"	38mm
HL-2-39	1-9/16"	-
HL-2-41	1-5/8"	41mm
HL-2-42	1-11/16"	-
HL-2-44	1-3/4"	-
HL-2-46	1-13/16"	46mm
HL-2-47	1-7/8"	-
HL-2-49	1-15/16"	49mm
HL-2-50	-	50mm
HL-2-51	2"	-
HL-2-52	2-1/16"	-
HL-2-54	2-1/8"	-
HL-2-55	2-3/16"	55mm
HL-2-57	2-1/4"	-
HL-2-59	2-5/16"	-
HL-2-60	2-3/8"	60mm

THL-4 Link	Hex Size	
	Imperial	Metric
HL-4-33	1-5/16"	-
HL-4-34	-	34mm
HL-4-35	1-3/8"	-
HL-4-36	-	36mm
HL-4-37	1-7/16"	-
HL-4-38	1-1/2"	38mm
HL-4-39	1-9/16"	-
HL-4-41	1-5/8"	41mm
HL-4-42	1-11/16"	-
HL-4-44	1-3/4"	-
HL-4-46	1-13/16"	46mm
HL-4-47	1-7/8"	-
HL-4-49	1-15/16"	49mm
HL-4-50	-	50mm
HL-4-51	2"	-
HL-4-52	2-1/16"	-
HL-4-53	2-1/8"	-
HL-4-55	2-3/16"	55mm
HL-4-57	2-1/4"	-
HL-4-58	2-5/16"	-
HL-4-60	2-3/8"	60mm
HL-4-61	2-7/16"	-
HL-4-63	2-1/2"	-
HL-4-65	2-9/16"	65mm
HL-4-66	2-5/8"	-
HL-4-68	2-11/16"	-
HL-4-70	2-3/4"	70mm
HL-4-71	2-13/16"	-
HL-4-73	2-7/8"	-
HL-4-75	2-15/16"	75mm
HL-4-76	3"	-
HL-4-77	3-1/16"	-
HL-4-79	3-1/8"	-
HL-4-80	-	80mm

THL-8 Link	Hex Size	
	Imperial	Metric
HL-8-41	1-5/8"	41mm
HL-8-42	1-11/16"	-
HL-8-44	1-3/4"	-
HL-8-46	1-13/16"	46mm
HL-8-47	1-7/8"	-
HL-8-49	1-15/16"	49mm
HL-8-50	-	50mm
HL-8-51	2"	-
HL-8-52	2-1/16"	-
HL-8-54	2-1/8"	-
HL-8-55	2-3/16"	55mm
HL-8-57	2-1/4"	-
HL-8-58	2-5/16"	-
HL-8-60	2-3/8"	60mm
HL-8-61	2-7/16"	-
HL-8-63	2-1/2"	-
HL-8-65	2-9/16"	65mm
HL-8-66	2-5/8"	-
HL-8-68	2-11/16"	-
HL-8-70	2-3/4"	70mm
HL-8-71	2-13/16"	-
HL-8-73	2-7/8"	-
HL-8-75	2-15/16"	75mm
HL-8-76	3"	-
HL-8-77	3-1/16"	-
HL-8-79	3-1/8"	-
HL-8-80	-	80mm
HL-8-81	3-3/16"	-
HL-8-82	3-1/4"	-
HL-8-84	3-5/16"	-
HL-8-85	-	85mm
HL-8-86	3-3/8"	-
HL-8-87	3-7/16"	-
HL-8-88	3-1/2"	-
HL-8-90	-	90mm
HL-8-91	3-9/16"	-
HL-8-92	3-5/8"	-
HL-8-93	3-11/16"	-
HL-8-95	3-3/4"	95mm
HL-8-96	3-13/16"	-
HL-8-98	3-7/8"	-
HL-8-100	3-15/16"	100mm
HL-8-101	4"	-
HL-8-103	4-1/16"	-
HL-8-105	4-1/8"	105mm

THL-14 Link	Hex Size	
	Imperial	Metric
HL-14-50	-	50mm
HL-14-51	2"	-
HL-14-52	2-1/16"	-
HL-14-53	2-1/8"	-
HL-14-55	2-3/16"	55mm
HL-14-57	2-1/4"	-
HL-14-58	2-5/16"	-
HL-14-60	2-3/8"	60mm
HL-14-62	2-7/16"	-
HL-14-63	2-1/2"	-
HL-14-65	2-9/16"	65mm
HL-14-66	2-5/8"	-
HL-14-68	2-11/16"	-
HL-14-70	2-3/4"	70mm
HL-14-71	2-13/16"	-
HL-14-73	2-7/8"	-
HL-14-75	2-15/16"	75mm
HL-14-76	3"	-
HL-14-77	3-1/16"	-
HL-14-79	3-1/8"	-
HL-14-80	-	80mm
HL-14-81	3-3/16"	-
HL-14-82	3-1/4"	-
HL-14-84	3-5/16"	-
HL-14-85	-	85mm
HL-14-86	3-3/8"	-
HL-14-87	3-7/16"	-
HL-14-89	3-1/2"	-
HL-14-90	-	90mm
HL-14-91	3-9/16"	-
HL-14-92	3-5/8"	-
HL-14-93	3-11/16"	-
HL-14-95	3-3/4"	95mm
HL-14-96	3-13/16"	-
HL-14-98	3-7/8"	-
HL-14-100	3-15/16"	100mm
HL-14-101	4"	-
HL-14-104	4-1/6"	-
HL-14-105	4-1/8"	105mm
HL-14-106	4-3/16"	-
HL-14-107	4-1/4"	-
HL-14-109	4-5/16"	-
HL-14-110	-	110mm
HL-14-111	4-3/8"	-
HL-14-112	4-7/16"	-
HL-14-114	4-1/2"	-
HL-14-115	-	115mm
HL-14-117	-	117mm

THL-32 Link	Hex Size	
	Imperial	Metric
HL-32-108	4-1/4"	-
HL-32-109	4-5/16"	-
HL-32-110	-	110mm
HL-32-111	4-3/8"	-
HL-32-112	4-7/16"	-
HL-32-114	4-1/2"	-
HL-32-115	-	115mm
HL-32-116	4-9/16"	-
HL-32-117	4-5/8"	117mm
HL-32-119	4-11/16"	-
HL-32-120	-	120mm
HL-32-121	4-3/4"	-
HL-32-122	4-13/16"	-
HL-32-123	4-7/8"	-
HL-32-125	-	125mm
HL-32-126	4-15/16"	-
HL-32-127	5"	127mm
HL-32-128	5-1/16"	-
HL-32-130	5-1/8"	-
HL-32-131	5-3/16"	-
HL-32-133	5-1/4"	-
HL-32-134	5-5/16"	135mm
HL-32-136	5-3/8"	-
HL-32-138	5-7/16"	-
HL-32-140	5-1/2"	140mm
HL-32-141	5-9/16"	-
HL-32-142	5-5/8"	-
HL-32-144	5-11/16"	-
HL-32-145	-	145mm
HL-32-146	5-3/4"	-
HL-32-147	5-13/16"	-
HL-32-149	5-7/8"	-
HL-32-150	-	150mm
HL-32-151	5-15/16"	-
HL-32-152	6"	-
HL-32-153	6-1/16"	-
HL-32-155	-	155mm
HL-32-156	6-1/8"	-
HL-32-157	6-3/16"	-
HL-32-158	6-1/4"	-
HL-32-160	-	160mm
HL-32-161	6-5/16"	-
HL-32-162	6-3/8"	-
HL-32-163	6-7/16"	-
HL-32-165	6-1/2"	165mm
HL-32-166	6-9/16"	-
HL-32-168	6-5/8"	-
HL-32-170	6-11/16"	170mm
HL-32-171	6-3/4"	-
HL-32-173	6-13/16"	-
HL-32-174	6-7/8"	-
HL-32-175	-	175mm

## HEAVY DUTY IMPACT SOCKETS:

The range of Imperial Impact Sockets with square drives is from 3/4" to 2.1/2" and the across flat sizes go up to 6.7/8 ". The Metric Impact Sockets offer 56 models with square drives ranging from 3/4" to 2.1/2" and across flat sizes up to 145mm.



**6 POINTS  
IMPACT SOCKETS**

Model No.	Square Drive	Nut A/F		D1	D2	S	T	L
		inch	mm					
TI424	3/4"	-	24	40	44	46	21	90
TI427	3/4"	-	27	41	44	48	23	90
TI427F	3/4"	1.1/16	-	41	44	48	23	90
TI430	3/4"	-	30	44	44	52	24	90
TI431F	3/4"	1.1/4	-	49	44	52	24	90
TI432	3/4"	-	32	49	44	52	26	90
TI436	3/4"	-	36	52	44	55	28	90
TI436F	3/4"	1.7/16	-	52	44	56	28	90
TI441	3/4"	-	41	57	44	59	36	90
TI441F	3/4"	1.5/8	-	57	44	59	36	90
TI446	3/4"	-	46	67	44	64	37	90
TI446F	3/4"	1.13/16	-	67	44	64	36	90
TI450	3/4"	-	50	70	54	67	39	90
TI451F	3/4"	2	-	73	54	67	39	90
TI455	3/4"	-	55	78	54	71	41	94
TI455F	3/4"	2.3/16	-	78	54	71	41	94
TI460	3/4"	-	60	82	52	75	45	98
TI460F	3/4"	2.3/8	-	82	54	75	45	98
TI524	1"	-	24	42	54	55	21	100
TI527	1"	-	27	46	54	55	23	100
TI527F	1"	1.1/16	-	46	54	55	23	100
TI530	1"	-	30	50	54	57	24	100
TI531F	1"	1.1/4	-	51	54	57	24	100
TI532	1"	-	32	51	54	57	26	100
TI536	1"	-	36	54	54	60	28	100
TI536F	1"	1.7/16	-	54	54	60	28	100
TI541	1"	-	41	63	54	64	36	100
TI541F	1"	1.5/8	-	63	54	64	36	100
TI546	1"	-	46	70	54	69	36	100
TI546F	1"	1.13/16	-	70	54	69	36	100
TI550	1"	-	50	73	54	72	36	100
TI551F	1"	2	-	73	54	72	39	100
TI555	1"	-	55	82	54	76	41	105
TI555F	1"	2.3/16	-	82	54	80	41	105
TI560	1"	-	60	86	54	82	45	112
TI560F	1"	2.3/8	-	88	54	85	45	112
TI565	1"	-	65	92	54	85	46	118
TI565F	1"	2.9/16	-	92	54	85	46	118
TI570	1"	-	70	96	54	88	50	124
TI570F	1"	2.3/4	-	96	54	88	50	124
TI575	1"	-	75	100	86	92	57	124
TI575F	1"	2.15/16	-	100	86	92	57	124
TI579F	1"	3.1/8"	-	105	86	97	57	132
TI580	1"	-	80	105	86	97	62	132
TI585	1"	-	85	115	86	100	62	132
TI588F	1"	3.1/2"	-	121	86	104	62	140
TI590	1"	-	90	127	86	104	62	140
TI595	1"	-	95	135	86	106	62	140
TI597F	1"	3.7/8"	-	135	86	112	62	143

Model No.	Square Drive	Nut A/F		D1	D2	S	T	L
		inch	mm					
TI5100	1"	-	100	135	86	112	62	143
TI636	1.1/2"	-	36	64	86	80	28	130
TI641	1.1/2"	-	41	69	86	83	32	130
TI646	1.1/2"	-	46	76	86	86	36	130
TI646F	1.1/2"	1.13/16	-	76	86	86	36	130
TI650	1.1/2"	-	50	81	86	90	39	130
TI651F	1.1/2"	2	-	81	86	90	39	130
TI655	1.1/2"	-	55	88	86	95	41	140
TI655F	1.1/2"	2.3/16	-	88	86	95	41	140
TI660	1.1/2"	-	60	96	86	98	45	140
TI660F	1.1/2"	2.3/8	-	96	86	98	45	140
TI665	1.1/2"	-	65	102	86	102	46	140
TI665F	1.1/2"	2.9/16	-	102	86	102	46	140
TI670	1.1/2"	-	70	108	86	102	50	150
TI670F	1.1/2"	2.3/4	-	108	86	102	50	150
TI675	1.1/2"	-	75	116	86	108	57	150
TI675F	1.1/2"	2.15/16	-	116	86	108	57	150
TI680	1.1/2"	-	80	120	86	110	62	150
TI680F	1.1/2"	3.1/8	-	120	86	110	62	150
TI685	1.1/2"	-	85	130	86	115	62	170
TI690	1.1/2"	-	90	135	125	118	65	170
TI690F	1.1/2"	3.1/2	-	135	125	118	65	170
TI695	1.1/2"	-	95	140	125	123	70	170
TI6100	1.1/2"	-	100	148	125	128	75	190
TI6100F	1.1/2"	3.7/8	-	148	125	128	75	190
TI6105	1.1/2"	-	105	155	125	133	80	190
TI6106F	1.1/2"	4.1/4	-	155	125	133	80	190
TI6110	1.1/2"	-	110	161	150	138	85	200
TI6115	1.1/2"	-	115	161	150	143	94	200
TI6120F	1.1/2"	4.5/8	-	175	150	149	94	200
TI780	2.1/2"	-	80	135	125	140	62	190
TI780F	2.1/2"	3.1/8	-	135	125	140	62	190
TI785	2.1/2"	-	85	140	125	140	62	190
TI790	2.1/2"	-	90	145	125	140	65	190
TI795	2.1/2"	-	95	155	125	150	70	190
TI796F	2.1/2"	3.7/8	-	155	125	150	70	190
TI7100	2.1/2"	-	100	160	125	150	75	200
TI7105	2.1/2"	-	105	165	125	160	80	200
TI7110	2.1/2"	-	110	174	150	160	85	210
TI7115	2.1/2"	-	115	180	150	170	90	210
TI7115F	2.1/2"	4.1/2	-	180	150	170	90	210
TI7125F	2.1/2"	5	-	195	150	175	98	220
TI7130	2.1/2"	-	130	195	150	175	98	220
TI7135F	2.1/2"	5.3/8	-	205	150	180	102	220
TI7145	2.1/2"	-	145	220	150	180	105	230
TI7145F	2.1/2"	5.3/4	-	220	150	180	105	230
TI7155F	2.1/2"	6.1/8	-	230	180	190	110	250
TI7165F	2.1/2"	6.1/2	-	240	180	200	120	-
TI7175F	2.1/2"	6.7/8	-	255	180	200	120	-



## TYPES OF SLUGGING WRENCHES

- ▶ Straight Ring Type
- ▶ Offset Handle Type
- ▶ Open Jaw Type
- ▶ Podger / Tommy Spanners
- ▶ Box Ring Type
- ▶ Square Drive Type Slugging Wrenches



WRENCH SIZE (A/F)		STRAIGHT RING TYPE			OFFSET HANDLE TYPE			OPEN JAW TYPE		
Metric mm	SAE inch	Head Diameter mm	Head Depth mm	Length mm	Head Diameter mm	Head Depth mm	Length mm	Head Diameter mm	Head Depth mm	Length mm
	3/16"	68	22	210	56	24	265	-	-	-
32	1.1/4"	68	22	210	58	25	270	80	18	210
33	1.5/16"	68	22	210	59	25	270	80	18	210
35	1.3/8"	68	22	210	62	28	290	80	18	210
36	1.7/6"	68	22	210	64	28	290	80	18	210
38	1.1/2"	68	22	210	66	28	290	80	18	210
41	1.5/8"	80	28	245	68	28	290	110	20	275
43	1.11/16"	80	28	245	68	28	290	110	20	275
44	1.3/4"	80	28	245	68	28	290	110	20	275
46	1.13/16"	80	28	245	76	32	340	110	20	275
47	1.7/8"	80	28	245	76	35	340	110	20	275
50	2"	80	28	245	82	36	340	110	22	275
52	2.1/16"	102	35	285	85	38	360	110	22	275
55	2.3/16"	102	35	285	90	38	360	110	22	275
57	2.1/4"	102	35	285	90	38	360	110	22	275
60	2.3/8"	102	35	285	96	41	380	110	22	275
62	2.7/16"	102	35	285	100	44	380	150	32	362
63	2.1/2"	102	35	285	102	44	380	150	32	362
65	2.9/16"	102	35	285	105	44	380	150	32	362
67	2.5/8"	122	40	322	108	44	380	150	32	362
70	2.3/4"	122	40	322	112	48	400	150	32	362
71	2.13/16"	122	40	322	112	50	400	163	32	400
75	2.15/16"	122	40	322	120	50	400	163	32	400
76	3"	122	40	322	122	50	400	163	32	400
80	3.1/8"	122	40	322	126	60	435	172	36	405
85	3.3/8"	130	40	340	132	60	435	180	38	430
90	3.5/8"	136	45	350	142	60	440	195	40	455
95	3.3/4"	140	45	375	150	60	465	195	40	455
98	3.7/8"	158	50	415	158	60	465	206	40	455
100	4"	158	50	415	164	60	465	210	47	500
105	4.1/8"	164	50	450	172	65	540	220	47	500
110	4.3/8"	170	55	450	180	65	540	226	47	500
115	4.1/2"	175	55	465	186	65	540	238	56	550
120	4.3/4"	175	60	490	194	70	540	247	56	550
125	4.7/8"	200	60	510	200	70	540	255	56	550
130	5"	210	65	515	205	70	540	275	60	575

NOTE : ALL SIZES ABOVE 130 mm ARE AVAILABLE ON REQUEST



**HEXAGON REDUCER BUSHES**

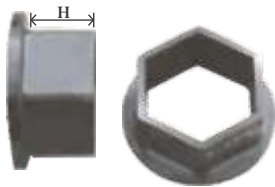

To reduce the female hexagon A/F size of the THL Series these Tritorc Hexagon Reducer Bushes offer an easy and economical solution. Just select your outside A/F size (i.e Ratchet Head A/F size) and the required inside A/F size to determine the Model number.

H= Height

Outside A/F size	Inside A/F size	THL-2	THL-4	THL-8	THL-14	THL-32
		Height-1.25"	Height-1.625"	Height-2.1"	Height-2.55"	Height-3.34"
		Model Number	Model Number	Model Number	Model Number	Model Number
1 1/4"	1 1/16"	HR-2-125-106	HR-4-125-106			
1 7/16"	1 1/16"	HR-2-143-106	HR-4-143-106			
1 7/16"	1 1/4"	HR-2-143-125	HR-4-143-125			
1 5/8"	1 1/4"	HR-2-162-125	HR-4-162-125			
1 5/8"	1 7/16"	HR-2-162-143	HR-4-162-143			
1 13/16"	1 7/16"	HR-2-181-143	HR-4-181-143			
1 13/16"	1 5/8"	HR-2-181-162	HR-4-181-162	HR-8-181-162		
2"	1 5/8"	HR-2-200-162	HR-4-200-162	HR-8-200-162		
2"	1 13/16"	HR-2-200-181	HR-4-200-181	HR-8-200-181		
2 3/16"	1 5/8"	HR-2-218-162	HR-4-218-162	HR-8-218-162		
2 3/16"	1 13/16"	HR-2-218-181	HR-4-218-181	HR-8-218-181		
2 3/16"	2"	HR-2-218-200	HR-4-218-200	HR-8-218-200		
2 3/8"	1 13/16"	HR-2-237-181	HR-4-237-181	HR-8-237-181		
2 3/8"	2"	HR-2-237-200	HR-4-237-200	HR-8-237-200	HR-14-237-200	
2 3/8"	2 3/16"	HR-2-237-218	HR-4-237-218	HR-8-237-218	HR-14-237-218	
2 9/16"	2"		HR-4-256-200	HR-8-256-200	HR-14-256-200	
2 9/16"	2 3/16"		HR-4-256-218	HR-8-256-218	HR-14-256-218	
2 9/16"	2 3/8"		HR-4-256-237	HR-8-256-237	HR-14-256-237	
2 3/4"	2 3/16"		HR-4-275-218	HR-8-275-218	HR-14-275-218	
2 3/4"	2 3/8"		HR-4-275-237	HR-8-275-237	HR-14-275-237	
2 3/4"	2 9/16"		HR-4-275-256	HR-8-275-256	HR-14-275-256	
2 15/16"	2 3/8"		HR-4-293-237	HR-8-293-237	HR-14-293-237	
2 15/16"	2 9/16"		HR-4-293-256	HR-8-293-256	HR-14-293-256	
2 15/16"	2 3/4"		HR-4-293-275	HR-8-293-275	HR-14-293-275	
3 1/8"	2 9/16"		HR-4-312-256	HR-8-312-256	HR-14-312-256	
3 1/8"	2 3/4"		HR-4-312-275	HR-8-312-275	HR-14-312-275	
3 1/8"	2 15/16"		HR-4-312-293	HR-8-312-293	HR-14-312-293	
3 1/2"	2 15/16"			HR-8-350-293	HR-14-350-293	
3 1/2"	3 1/8"			HR-8-350-312	HR-14-350-312	
3 7/8"	3 1/8"			HR-8-387-312	HR-14-387-312	
3 7/8"	3 1/2"			HR-8-387-350	HR-14-387-350	
4 1/8"	3 1/2"			HR-8-412-350	HR-14-412-350	
4 1/8"	3 7/8"			HR-8-412-387	HR-14-412-387	
4 5/8"	3 7/8"					
4 5/8"	4 1/4"					HR-32-462-425
5"	4 1/4"					HR-32-500-425
5"	4 5/8"					HR-32-500-462
5 5/16"	4 5/8"					HR-32-531-462
5 5/16"	5"					HR-32-531-500
5 3/4"	5"					HR-32-575-500
5 3/4"	5 3/8"					HR-32-575-573
6 1/8"	5 3/8"					HR-32-612-573
6 1/8"	5 3/4"					HR-32-612-575
6 1/2"	5 3/4"					HR-32-650-575
6 1/2"	6 1/8"					HR-32-650-612
6 7/8"	6 1/8"					HR-32-687-612
6 7/8"	6 1/2"					HR-32-687-650
7 3/16"	6 1/2"					HR-32-718-650
7 3/16"	6 7/8"					HR-32-718-687
7 7/16"	6 7/8"					HR-32-744-687
7 7/16"	7 3/16"					HR-32-744-718
7 5/8"	6 7/8"					HR-32-762-687
7 5/8"	7 1/16"					HR-32-762-744
7 7/8"	7 7/16"					HR-32-787-744
7 7/8"	7 5/8"					HR-32-787-762

# METRIC HEXAGON REDUCER BUSHES



Outside A/F size	Inside A/F size	THL-2	THL-4	THL-8	THL-14	THL-32
		Height-32mm	Height-42mm	Height-53mm	Height-64mm	Height-85mm
		Model number	Model number	Model number	Model number	Model number
30	24	HR-2-30-24				
32	24	HR-2-32-24				
32	27	HR-2-32-27				
36	30	HR-2-36-30				
41	36	HR-2-41-36	HR-4-41-36			
46	36	HR-2-46-36	HR-4-46-36			
46	41	HR-2-46-41	HR-4-46-41	HR-8-46-41		
50	41	HR-2-50-41	HR-4-50-41	HR-8-50-41		
50	46	HR-2-50-46	HR-4-50-46	HR-8-50-46		
55	41	HR-2-55-41	HR-4-55-41	HR-8-55-41		
55	46	HR-2-55-46	HR-4-55-46	HR-8-55-46		
55	50	HR-2-55-50	HR-4-55-50	HR-8-55-50		
60	46	HR-2-60-46	HR-4-60-46	HR-8-60-46		
60	50		HR-4-60-50	HR-8-60-50	HR-14-60-50	
60	55		HR-4-60-55	HR-8-60-55	HR-14-60-55	
65	50		HR-4-65-50	HR-8-65-50	HR-14-65-50	
65	55		HR-4-65-55	HR-8-65-55	HR-14-65-55	
65	60		HR-4-65-60	HR-8-65-60	HR-14-65-60	
70	55		HR-4-70-55	HR-8-70-55	HR-14-70-55	
70	60		HR-4-70-60	HR-8-70-60	HR-14-70-60	
70	65		HR-4-70-65	HR-8-70-65	HR-14-70-65	
75	60		HR-4-75-60	HR-8-75-60	HR-14-75-60	
75	65		HR-4-75-65	HR-8-75-65	HR-14-75-65	
75	70		HR-4-75-70	HR-8-75-70	HR-14-75-70	
80	65		HR-4-80-65	HR-8-80-65	HR-14-80-65	
80	70		HR-4-80-70	HR-8-80-70	HR-14-80-70	
80	75		HR-4-80-70	HR-8-80-75	HR-14-80-75	
85	70			HR-8-85-70	HR-14-85-70	
85	75			HR-8-85-75	HR-14-85-75	
85	80			HR-8-85-80	HR-14-85-80	
90	75			HR-8-90-75	HR-14-90-75	
90	80			HR-8-90-80	HR-14-90-80	
90	85			HR-8-90-85	HR-14-90-85	
95	80			HR-8-95-80	HR-14-95-80	
95	85			HR-8-95-85	HR-14-95-85	
95	90			HR-8-95-90	HR-14-95-90	
100	85			HR-8-100-85	HR-14-100-85	
100	90			HR-8-100-90	HR-14-100-90	
100	95			HR-8-100-95	HR-14-100-95	
105	90			HR-8-105-90	HR-14-105-90	
105	95			HR-8-105-95	HR-14-105-95	
105	100			HR-8-105-100	HR-14-105-100	
110	95				HR-14-110-95	HR-32-110-95
110	100				HR-14-110-100	HR-32-110-100
110	105				HR-14-110-105	HR-32-110-105
115	100				HR-14-115-100	HR-32-115-100
115	105				HR-14-115-105	HR-32-115-105
115	110				HR-14-115-110	HR-32-115-110
135	110					HR-32-135-110
135	115					HR-32-135-110
135	120					HR-32-135-130
145	110					HR-32-145-110
145	115					HR-32-145-115
145	130					HR-32-145-130
160	130					HR-32-160-130
160	145					HR-32-160-145
175	145					HR-32-175-145
175	160					HR-32-175-160

## FULLY AUTOMATIC ELECTRIC POWER PACK

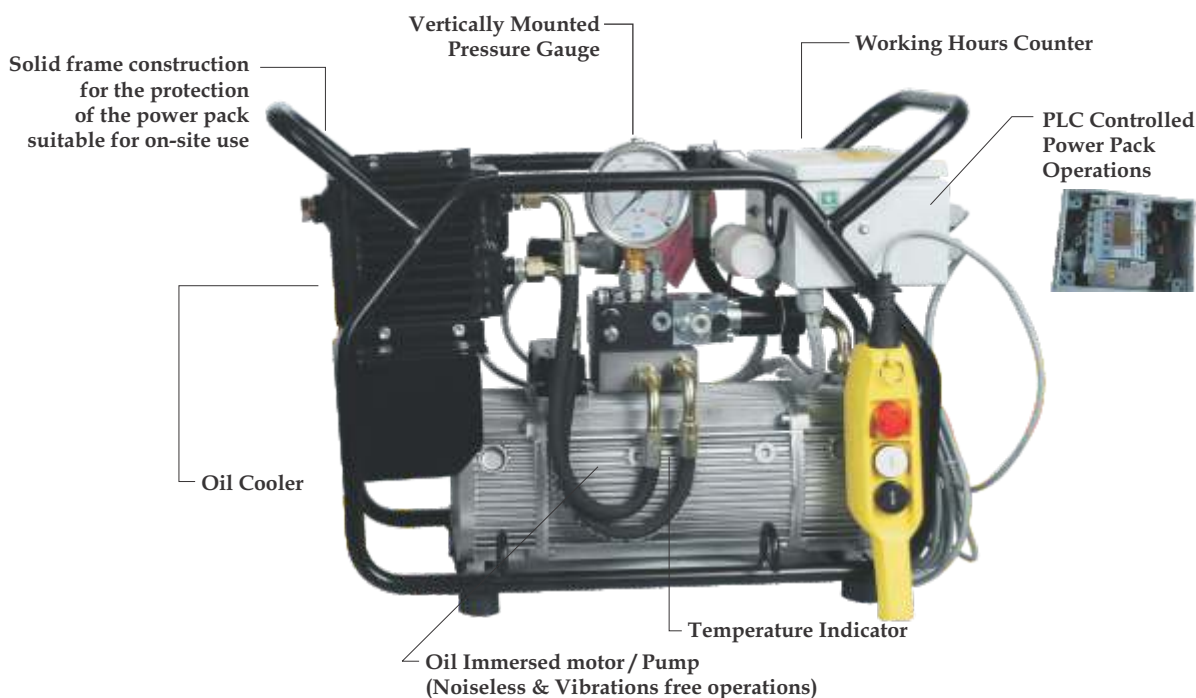

### EQUIPPED WITH ALL SAFETY FEATURES

- Note :
- Also available as Conventional Electric Powerpack
  - Pump will be supplied with Remote control Pendant

### Technical Specification

Model No	: HPL101
Power Rating	: 1.5HP
Maximum Pressure	: 800Bar
Flow Rate	: 9.7LPM @ 100Bar 0.97 LPM @ 800Bar
Capacity	: 8 Lt.

With auto cycle



Without auto cycle

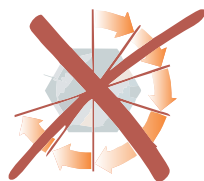

### ADVANTAGES OF FULLY AUTOMATIC TRITORC POWER PACKS

#### 1. Fully Automatic Power Pack

- ▶ Faster and reliable in operations
- ▶ High repeatability of the bolting process without pressing the button again and again.

#### 2. Temperature Management

- ▶ In built heat exchanger to cool the system.
- ▶ The unique concept of the high- speed cooling and heat exchanger optimizes cooling for continuous operation.
- ▶ Powerpack switches off automatically if temperature rises above 800 C.

#### 3. Oil immersed Motor

- ▶ Noiseless and vibration free operations
- ▶ Effective temperature equalization by cooling motor, pump & oil at the same time.

#### 4. PLC Controlled System

- ▶ Effectively controlled operations of power packs
- ▶ If the power pack operates continuously more than 3 minutes idle, it gets switched off automatically.

# TRITROC AIR OPERATED HYDRAULIC TORQUE WRENCH POWER PACK

700 bar  
Single-two speed  
0.9/0.45 - 7.9/0.9 cm<sup>3</sup> oil flow



Model	Pressure 1 <sup>st</sup> -2 <sup>nd</sup> STAGE (bar)	Flow Rate 1 <sup>st</sup> -2 <sup>nd</sup> STAGE (l/min)	Motor	Km RPM	Reservoir Capacity (liters)	Weight (kg)
APL100	70/700	7.9 / 0.9	PNEUMATIC	2.6 / 3000	10	36

APL-100

## ADVANTAGES OF AIR OPERATED POWER PACKS

- ▶ Powered by a rotary air vane, 3 hp motor (3,000 rpm).
- ▶ Equipped with a filter-lubricator assembly, air muffler, adjustable relief and 12' remote controlled pendant on all models.
- ▶ High performance two-stage pump provides higher cross-over pressure for faster cycle times and tool operation; 55 cubic inches / minute @ 10,000 PSI.

# ATEX CERTIFIED ELECTRIC PUMP FOR HAZARDOUS ZONES



## Tritorc Model: PHE-ATEX

### FEATURES:

Hydraulic Pump With Three-phase Electric Motor  
ATEX Certified Version Ce Ex Ii 2 G K T3  
ATEX Zone-2 Class T3 Gas Group IIA

- ▶ Three-phase electric motor 1.1 kW 440V
- ▶ Axial-piston pump mod.
- ▶ Oil flow 9.4 litres/min @ 0-70 bar and 0.9 litres/min @ 700 bar
- ▶ 3/2 solenoid valve 24 DC and inversion valve
- ▶ Pressure regulator on P line to set the torque value
- ▶ Adjustable Relief Valve on return line
- ▶ Pressure gauge DN 100 0-1000 bar
- ▶ Reservoir Capacity 10 litres
- ▶ Recommended hydraulic oil ISO 32
- ▶ The pump includes remote control and electric box

- ▶ Also available in air operated type (PAE - ATEX)



TRITORC SL-Series Light Weight and Compact Shear Wrenches provide consistent, reliable Torque Tightening and Shearing to the Tension Control Bolts.

TRITORC Electric Shear Wrenches are capable of achieving Controllable Torque Range of 5000 Nm with supported Bolt Sizes till M36.

All our Shear Wrenches are calibrated and certified on in-house test bench in our facility.



Model No.	Bolt Sizes (mm)	Torque (Nm)	Speed (Rpm)	Weight (Kg)
SL-16	M12, M16	320	36	3.8
SL-20	M12, M16, M20	540	24	6
SL-22	M16, M20, M22	910	20	6.8
SL-24	M20, M22, M24	1200	14	8
SL-27	M22, M24, M27	1700	12	8.3
SL-30	M24, M27, M30	2500	5	10.5
SL-33	M27, M30, M33	3500	4.5	15
SL-36	M30, M33, M36	5000	2.5	17

# ET SERIES ELECTRIC TORQUE WRENCH

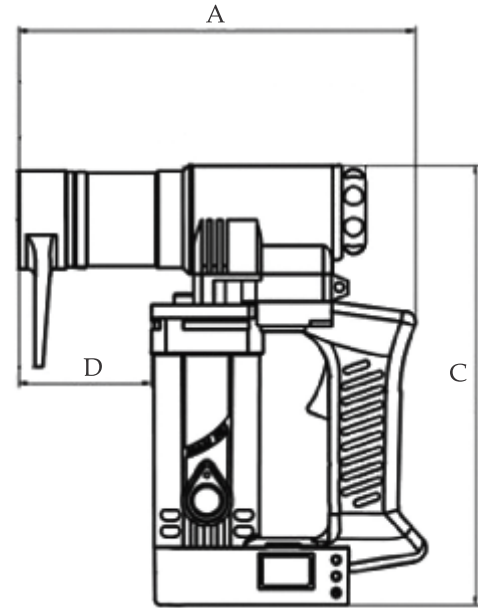

Model	Torque (Nm)	Direct Hex Available	Speed (RPM)	Weight (kg)	Overall Length A (mm)	Overall Width C	Diameter D
ET-3	100-300	M10, M12, M16	28	4	240	267	80
ET-5	200-500	M12, M16, M20	20	4.2	271	267	111
ET-7	300-700	M16, M20, M22	18	4.6	221	269	54
ET-9	400-900	M20, M22, M24	16	5.1	238	275	71
ET-12	500-1200	M22, M24, M27	14	6.3	225	287	50
ET-17	800-1700	M24, M27, M30	12	7	286	287	81
ET-21	1000-2100	M27, M30, M33	10	7.2	274	286	95
ET-25	1100-2500	M30, M33, M36	5	9	283	293	107
ET-35	1700-3500	M33, M36, M42	4.5	15	283	293	107
ET-50	2000-5000	M42, M45, M48	2.5	17	375	301	273

Model	Torque Range (Nm)	Speed (RPM)	Weight (Kg)	Square Drive
ES-3	100-300	28	4	3/4"
ES-5	200-500	20	4.2	3/4"
ES-7	300-700	18	4.6	1"
ES-9	400-900	16	5.1	1"
ES-12	500-1200	14	6.3	1"
ES-17	800-1700	4.5	7.0	1.1/2"
ES-21	1000-2100	5.5	7.2	1.1/2"
ES-25	1000-2500	5	9	1.1/2"
ES-35	1700-3500	4.5	15	1.1/2"
ES-40	2000-4000	3	17	1.1/2"
ES-60	3000-6000	2.5	18	1.1/2"
ES-100	5000-10000	2.5	21	2.1/2"



## A PRECISION TOOL cum INSTRUMENT:

TRITORC Click type Torque Wrenches are of an **innovative** design concept providing consistently accurate readings and rugged (Trouble Free) performance. Our Torque Wrenches have a proven performance record and we offer a **Free Replacement Guarantee** on our complete range of Torque Wrenches, against any premature failure.



MODEL NO.		TORQUE WRENCHES				SQUARE DRIVE	OVERALL LENGTH	UNIT WEIGHT
Non-Ratcheting	Ratcheting	Nm	Kgf.m	Lbf.in	Lb.ft	Inches	mm	kgs.
TVT-100A	TVTR-100A	2.5-11	0.3-1.1	20-100	2-8	3/8"	320/360	0.56
TVT-300A	TVTR-300R	5-35	0.5-3.5	40-300	4-25	3/8"	430/465	0.75
TVT-600A	TVTR-600R	12-68	1.2-7	100-600	10-50	1/2"	485/530	1.10
TVT-1200A	TVTR-1200A	25-135	3-14	200-1200	20-100	1/2"	545/595	2.0
TVT-2000A	TVTR-2000A	50-225	5-23	400-2000	40-160	1/2"	610/660	2.49
TVT-3000A	TVTR-3000A	70 - 330	7-35	600-3000	50 - 250	1/2"	835/890	4.0
TVT-5000A	TVTR-5000A	140 - 560	14-57	1200-5000	100-410	3/4"	1120/1195	6.58
TVT-8400A	TVTR-8400A	480 - 940	49-95	4200-8400	350-700	1"	1400/1485	12.7
NT-14	NT-14/R	135-540	14-56	1200-4800	100-400	3/4"	1120/1195	6.5
NT-14S	NT-14S/R	135-780	14-78	1200-6640	100-500	3/4"	1110/1195	7.0
NT-49	NT-49/R	475-1050	49-105	4200-9300	350-750	3/4"	1390/1480	15.0
NT-55	NT-55/R	540-1380	55-140	4800-12250	400-1000	1"	1305/1340	18.0
NT-105	NT-105/R	1015-1900	105-195	8800-16820	750-1400	1"	1305/1340	18.0
NT-170	NT-170/R	1350-2700	135-275	11950-24000	1000-2000	1"	1450/1530	20.60

We also offer Torque Wrenches of following types:

### Open Jaw Fixed Head Type

These types of Torque Wrenches are available in standard Across Flat sizes from 10 mm to 46 mm with torque preset to one value as per bolt torque capacity or customer requirement. These torque wrenches can be used directly on bolt, there is no need of sockets.



### Bi-Hex Ring Type

These types of Torque Wrenches are available in standard Across Flat sizes from 10 mm to 46 mm with torque preset to one value as per bolt torque capacity or customer requirement. These torque wrenches can be used directly on bolt, there is no need of sockets.



### Preset Torque Production Type

These types of Torques Wrenches are designed specifically for use on production lines where many fasteners are to be tightened to the same torques value. It improves working efficiency of workmen and the production works will complete.



# MANUAL TORQUE WRENCHES

## TQL TORQUE WRENCH Industrial Torque



ITEM NO.	Square Drive	RangeL	Kg	
			mm	Kg
TQL-30N	1/4" or 3/8"	6-30 Nm	350	0.74
TQL-110N	3/8"	19-110 Nm	385	0.96
TQL-210N	1/2"	40-210 Nm	535	1.70
TQL-330N	1/2"	70-350 Nm	645	2.54
TQL-500N	3/4"	100-500 Nm	865	3.66
TQL-700N	3/4"	140-700 Nm	1092	5.94
TQL-980N	3/4" or 1"	140-980 Nm	1230	6.46
TQL-1500N	1"	300-1500Nm	1700	11.58

ITEM NO.	Square Drive	RangeL	Kg	
			mm	Kg
TQL-250i	1/4" or 3/8"	40-250 in.lb.	350	0.74
TQL-80F	3/8"	15-80 ft.lb.	385	0.96
TQL-150F	1/2"	30-150 ft. lb.	535	1.70
TQL-250F	1/2"	50-250 ft. lb.	645	2.54
TQL-300F	3/4"	50-300 ft. lb.	865	3.66
TQL-600F	3/4"	100-600 ft. lb.	1092	5.94
TQL-700F	3/4" or 1"	100-700 ft. lb.	1230	6.46
TQL-1000F	1"	200-1000 ft. lb.	1700	11.58

## TSP TORQUE WRENCH Pre-Set Torque



ITEM NO.	Square Drive	Range	Kg	
			L mm	Kg
TSP-12N	1/4"	2.12 Nm	193	0.22
TSP-50N	3/8"	5-50 Nm	298	0.56
TSP-100N	3/8"	15-100 Nm	365	0.76
TSP-200N	1/2"	50-200 Nm	508	1.38

ITEM NO.	Square Drive	Range	Kg	
			L mm	Kg
TSP-120i	1/4"	20-120 in.lb	193	0.22
TSP-40F	3/8"	4-40 ft.lb	298	0.56
TSP-80F	3/8"	10-80 ft.lb	365	0.76
TSP-150F	1/2"	40-150 ft.lb	508	1.38

## TAP INTERCHANGEABLE TORQUE HANDLE Adjustable Torque



ITEM NO.	mm	Range	Kg	
			L mm	Kg
TAP-30N	9x12	6-30 Nm	280	0.75
TAP-80N	9x12	15-80 Nm	355	0.88
TAP-80NS	14x18	15-80 Nm	360	0.90
TAP-110N	9x12	19-110 Nm	368	0.94
TAP-110NS	14x18	19-110 Nm	373	0.96
TAP-210N	14x18	40-210 Nm	509	1.50

ITEM NO.	mm	Range	Kg	
			L mm	Kg
TAP-250i	9x12	50-250 in.lb	280	0.75
TAP-60F	9x12	10-60 ft.lb	355	0.88
TAP-60FS	14x18	10-60 ft.lb	360	0.90
TAP-80F	9x12	15-80 ft.lb	368	0.94
TAP-80FS	14x18	15-80 ft.lb	373	0.96
TAP-150F	14x18	30-150 ft.lb	509	1.50

## TSH INTERCHANGEABLE OPEN ENDED HEADS

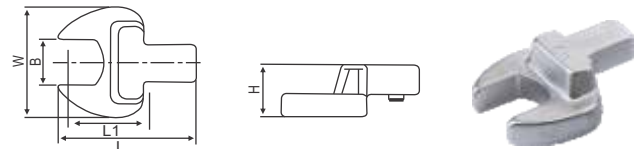

ITEM NO.	mm		W mm	H mm	L mm	L1 mm	Kg
	B mm	mm					
TSH0912-7m	7	9x12	24.0	5.5	37.0	17.5	38
TSH0912-8m	8	9x12	24.0	5.5	37.0	17.5	38
TSH0912-9m	9	9x12	24.0	6.0	37.5	17.5	39
TSH0912-10m	10	9x12	30.0	6.0	38.5	17.5	42
TSH0912-11m	11	9x12	30.0	6.0	38.5	17.5	43
TSH0912-12m	12	9x12	30.0	7.0	39.5	17.5	48
TSH0912-13m	13	9x12	30.0	7.0	42.0	20.0	52
TSH0912-14m	14	9x12	30.0	7.0	42.0	20.0	59
TSH0912-15m	15	9x12	35.0	8.0	43.0	20.0	59
TSH0912-16m	16	9x12	38.0	8.0	44.5	20.0	67
TSH0912-17m	17	9x12	38.0	8.5	44.5	20.0	67
TSH0912-18m	18	9x12	42.0	8.5	44.5	22.0	75
TSH0912-19m	19	9x12	42.0	8.5	46.0	22.0	75

ITEM NO.	mm		W mm	H mm	L mm	L1 mm	Kg
	B mm	mm					
TSH1418-13m	13	14x18	35.0	7.0	62.5	32.0	148
TSH1418-14m	14	14x18	35.0	8.0	63.0	32.0	154
TSH1418-15m	15	14x18	35.0	8.5	64.0	32.0	154
TSH1418-16m	16	14x18	38.0	9.0	64.0	32.0	173
TSH1418-17m	17	14x18	38.0	9.0	64.0	32.0	173
TSH1418-18m	18	14x18	42.0	10.0	65.0	32.0	192
TSH1418-19m	19	14x18	42.0	10.5	65.0	32.0	193
TSH1418-21m	21	14x18	50.0	11.0	66.0	32.0	217
TSH1418-22m	22	14x18	52.5	11.0	66.0	32.0	222
TSH1418-24m	24	14x18	53.0	11.0	67.0	32.0	225
TSH1418-26m	26	14x18	60.0	12.5	70.0	34.0	273
TSH1418-27m	27	14x18	60.0	12.5	70.0	34.0	281
TSH1418-29m	29	14x18	66.0	14.0	74.0	36.0	312
TSH1418-30m	30	14x18	66.0	14.0	74.0	36.0	312
TSH1418-32m	32	14x18	66.0	14.5	76.5	37.5	322



# MANUAL TORQUE MULTIPLIER

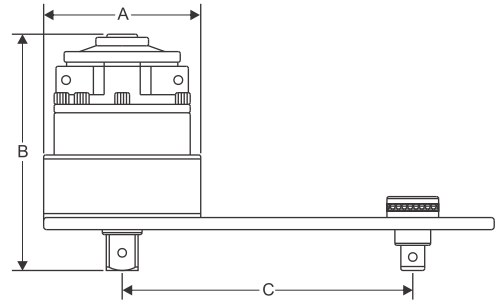

## Specifications :

HAND TORQUE MODEL NO.	MAXIMUM OUTPUT TORQUE			ESTIMATED BOLT CAPACITY (S. QUALITY)		MULTIPLICATION FACTOR	FEMALE INPUT SQUARE	MALE OUTPUT SQUARE	MAJOR DIA A	DEPTH B	MIN C	MAX C	RECOMMENDED TORQUE WRENCH	APPROX. WEIGHT WITH REACTION PLATE
	Ft. lbs	Nm.	Kgf.m.	in.	mm									
AM-1	1250	1700	170	1.1/8	27	5	1/2	3/4	115	87	75	164	TVT-3000A	4.5
AM-2	1250	1700	170	1.1/8	27	5	3/4	1	115	90	75	164	TVT-3000A	5.0
AM-2/25 <small>Fitted with AWUR</small>	1250	1700	170	1.1/8	27	25	1/2	1	115	120	75	164	TVT-600A	7.0
AM-5	2000	2700	275	1.3/8	36	5	3/4	1	136	135	89	260	TVT-5000A	11.0
AM-5/25 <small>Fitted with AWUR</small>	2000	2700	275	1.3/8	36	25	1/2	1	136	163	89	260	TVT-1200A	11.0
AM-6	2500	3400	345	1.1/2	38	5	3/4	1.1/2	136	149	105	260	TVT-8400A	8.5
AM-6/25	2500	3400	345	1.1/2	38	25	1/2	1.1/2	136	176	105	260	TVT-1200A	11.5
AM-7	4500	6000	622	1.7/8	48	5	3/4	1.1/2	168	174	115	310	NT-55	18.0
AM-7/25 <small>Fitted with AWUR</small>	4500	6000	622	1.7/8	48	25	1/2	1.1/2	168	226	115	310	NT-55	22.0
AM-9/25 <small>Fitted with AWUR</small>	7000	9500	965	2.1/4	56	25	3/4	1.1/2	195	256	150	350	TVT-5000A	33.0
AM-9/125 <small>Fitted with AWUR</small>	7000	9500	965	2.1/4	56	125	1/2	1.1/2	195	301	150	350	NT-14/S	35.5
AM-11/25 <small>Fitted with AWUR</small>	12500	17000	1735	3.3/4	95	25	3/4	2.1/2	220	360	164	480	NT-14/S	52.0
AM-11/125 <small>Fitted with AWUR</small>	12500	17000	1735	3.3/4	95	125	1/2	2.1/2	220	404	164	480	TVT-2000A	57.0
AM-13/125 <small>Fitted with AWUR</small>	35000	47500	4845	4.1/2	115	125	3/4	2.1/2	315	550	164	480	NT-14/R	80.0

## AWUR-Anti Wind Up Ratchet



MODEL NO.	Gear Ratio	Torque Capacity Max.		Height	Diameter	Weight	Input Drive	Output Drive	Suitable for Bolt Size	
		Ft. lbs	Nm						Thread Size	A/F
TVR:15	4.5 : 1	1000	1355	175	80	3.0	3/4"	1"	M16 - M27	24 - 41
TVR:25	12 : 1	1350	1630	310	80	5.2	3/4"	1"	M20 - M30	30 - 46
TVR:35	15 : 1	2125	2880	285	80	5.1	3/4"	1"	M20 - M36	30 - 55
TVR:40	15 : 1	2360	3200	245	95	6.1	3/4"	1.1/2"	M20 - M39	30 - 60
TVR:65	21 : 1	3660	4960	240	114	8.4	3/4"	1.1/2"	M27 - M42	41 - 65
TVR:90	40 : 1	5075	6880	300	172	21.5	3/4"	1.1/2"	M33 - M48	50 - 75

## 3/4" HEAVY DUTY IMPACT WRENCH



Model No.	Torque Max (Nm)	Free Speed	Air Inlet	Length	Weight
		(rpm)	(Inch)	(mm)	(kg)
PL 42	1493	4000	3/8"	257	5.1
PL 41	1086	4800	1/4"	243	5.1
PL 40	1900	5500	3/8"	229	3.4

## 1/2" HEAVY DUTY IMPACT WRENCH



Model No.	Torque Max (Nm)	Free Speed	Air Inlet	Length	Weight
		(rpm)	(Inch)	(mm)	(kg)
PL 32	651	7000	1/4"	185	2.55
PL 31	516	7000	1/4"	190	2.7
PL 30	1357	7500	1/4"	193	1.9

## 1-1/2" HEAVY DUTY IMPACT WRENCH



PL 6

Model No.	Torque Max (Nm)	Free Speed	Air Inlet	Length	Weight
		(rpm)	(Inch)	(mm)	(kg)
PL-6	4,068 N-M	3,000	1/2"	475	15.05

## 1" HEAVY DUTY IMPACT WRENCH



PL 52 L

PL 52

PL 51

Model No.	Torque Max (Nm)	Free Speed	Air Inlet	Length	Weight
		(rpm)	(Inch)	(mm)	(kg)
PL 52L	3661	3000	1/2"	628	16.5
PL 52	2445	3500	1/2"	300	9
PL 51	1627	4000	1/2"	254	6.3

## 3/8" HEAVY DUTY IMPACT WRENCH



PL 22

PL 21

PL 20

Model No.	Torque Max (Nm)	Free Speed	Air Inlet	Length	Weight
		(rpm)	(Inch)	(mm)	(kg)
PL 22	325	10,000	1/4"	155	1.5
PL 21	244	10,000	1/4"	162	1.35
PL 20	407	12,000	1/4"	168	1.2

## ACCESSORIES FOR PNEUMATIC & HYDRAULIC TOOLS



4-WAY MULTI SPLIT BLOCK



QUICK CONNECT COUPLINGS



HYDRAULIC HOSES

# TOP-SIDE BOLT TENSIONER

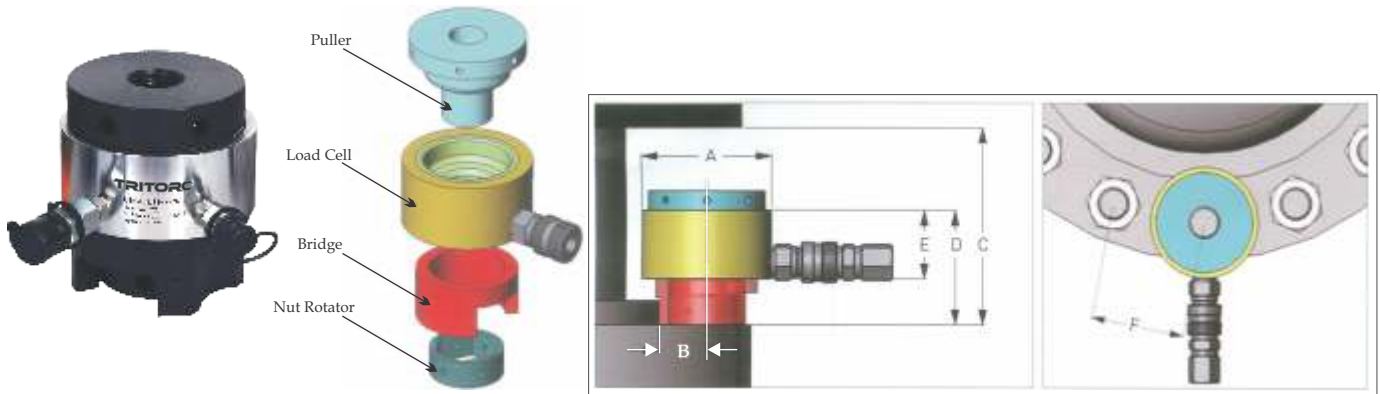

Model	Bolt size		Cylinder	Area	Dimension						Weight		
	Metric	Inch			KN	cm <sup>2</sup>	A	B	C	D		E	F
							mm	mm	mm	mm		mm	mm
BTL-3	M16	-	234.2	15.7	75	32.5	168	90	62	47-51	2		
	M18	3/4"											
	M20	-											
	M22	7/8"											
BTL-5	M24	1	498.2	33	102	47	187	106	60	65-71	4		
	M27	1-1/8"											
	M30	-											
	M33	1-1/4"											
	M36	1-3/8"											
BTL-9	M39	1-1/2"	896.8	59.7	133	61	208	120	60	86-93	6		
	M42	1-5/8"											
	M45	1-3/4"											
	M48	1-7/8"											
BTL-13	M52	2"	1245.5	83	163	73	231	135	62	106-114	10		
	M56	2-1/4"											
	M60	-											
	M64	2-1/2"											
BTL-19	M64	2-1/2"	1843.3	123	193	86.5	254	150	62	129-135	15		
	M68	-											
	M72	2-3/4"											
	M76	3"											
BTL-27	M76	3"	2640.5	176	233	110	286	180	73	155-167	24		
	M80	-											
	M85	3-1/4"											
	M90	3-1/2"											
	M95	3-3/4"											
BTL-44	M100	4"	4384.2	251	280	111-121	304-338	181-197	37-40	210-233	45		
	M110	4-1/2"											
	M120	4-3/4"											
BTL-54	M125	5"	5380.5	317	325	126-141	354-388	202-216	42-47	243-275	73		
	M130	5-1/4"											
	M140	5-1/2"											
	M150	5-3/4"											

Note: Dimensions are subject to change as per customer requirement.

## SLT SERIES SPRING RETURN HYDRAULIC BOLT TENSIONER



- ▶ Working pressure 1500 bar / 21755 psi
- ▶ Special seal kit, piston/cylinder mis-alignment compensation
- ▶ Piston stroke of SLT1=8mm, the other model is 10mm
- ▶ Built-in stroke limit valve prevent over stroke
- ▶ Fully enclosed load cell to prevent debris into cylinder
- ▶ Spring return, fast, safety

Model	Bolt Size		Max. Load (KN)	Hyd. Area (cm <sup>2</sup> )	A(mm)	B(mm)	C(mm)	D(mm)	Weight (kg)
	Imperial	Metric							
SLT1	3/4" SLT1-1	M20 SLT1-3	160	10.67	66	93	63	136	1.4
	7/8" SLT1-2	M22 SLT1-4							
SLT2	1" SLT2-1	M24 SLT2-3	280	18.67	87	117	68	175	2.7
	1-1/8" SLT2-2	M27 SLT2-4							
SLT3	1" SLT3-1	M24 SLT3-5	450	30.01	103	117	75	175	4.1
		M27 SLT3-6				117	75	175	
	1-1/8" SLT3-2	M30 SLT3-7				120	80	181	
	1-1/4" SLT3-3	M33 SLT3-8				123	84	188	
	1-3/8" SLT3-4	M36 SLT3-9			126	89	195		
SLT4	1-1/4" SLT4-1	M33 SLT4-5	660	44.01	118	123	88	190	5.4
	1-3/8" SLT4-2	M36 SLT4-6				126	96	197	
	1-1/2" SLT4-3	M39 SLT4-7				130	96	203	
	1-5/8" SLT4-4	M42 SLT4-8				133	105	209	
SLT5	1-1/2" SLT5-1	M39 SLT5-6	1000	66.68	140.5	132	112	211	8.4
	1-5/8" SLT5-2	M42 SLT5-7				135	114	217	
	1-3/4" SLT5-3	M45 SLT5-8				139	118	223	
	1-7/8" SLT5-4	M48 SLT5-9				142	114	230	
	2" SLT5-5					145	120	236	
SLT6	2" SLT6-1	M52 SLT6-5	1500	100.03	175.5	148	120	246	13.8
	2-1/4" SLT6-1	M56 SLT6-6				154	138	259	
		M60 SLT6-7				161	138	259	
	2-1/2" SLT6-3	M64 SLT6-8				161	153	272	
	2-3/4" SLT6-4	M68 SLT6-9			167	156	284		
SLT7	2-3/4" SLT7-1	M72 SLT7-5	2500	166.71	219	167	157	294	23
	3" SLT7-2	M76 SLT7-6				171	158	307	
		M80 SLT7-7				180	190	310	
	3-1/4" SLT7-3	M85 SLT7-8				180	190	320	
	3-1/2" SLT7-4	M90 SLT7-9				186	205	332	
SLT8	3-1/2" SLT8-1	M90 SLT8-4	3200	213.39	252	186	200	339	32
		M95 SLT8-5				186	200	346	
	3-3/4" SLT8-2	M100 SLT8-6				192	200	352	
	4" SLT8-3					199	210	364	

Note: Dimensions are subject to change as per customer requirement.



## MST SERIES MULTI-STAGE HYDRAULIC BOLT TENSIONER



- ▶ Working pressure 1500 bar / 21755 psi
- ▶ Fast, simple, accuracy, reliable, ideal tightening and bolting tools for wind turbine
- ▶ Small, compact, large load
- ▶ Durable composite material seal kit
- ▶ Clear over stroke alarming mark
- ▶ Optional gear drive rotate nut quickly

Model	Bolt Diameter		The Min. Length of Thread (mm)	The Max. Length of Thread (mm)	Working Stroke (mm)	Bolt Distance (mm)	Max. Load (Kn)	Outside Diameter (mm)	Min. Height (mm)
	(mm)	(in)							
MST-M30	M30	1-1/8	62	69	7	66	464	73	276
MST-M33	M33	1-1/4	66	73	9	72	583	78	295
MST-M36	M36	1-3/8	75	82	9	77	677	84	326
MST-M39	M39	1-1/2	78	88	10	83	805	90	360
MST-M42	M30	1-5/8	83	91	10	89	926	96	357
MST-M45	M42	1-3/4	87	96	10	96	1091	105	371
MST-M48	M48	1-7/8	93	102	10	102	1231	110	387



Note: Dimensions are subject to change as per customer requirement.

TRITORC Subsea Bolt Tensioners are manufactured to suit the demanding requirements of divers working in harsh subsea environments. We provide a complete range of Subsea Tensioners which incorporate the Split Reaction Nut benefitting divers by saving time by saving time and by ensuring the fastest possible reaction nut engagement.



- ▶ Cover full range of bolt sizes from 1" to 3.1/2"
- ▶ Up to work load of 253 Tonnage Force

Model		Bolt Dia.		Max Load		Hydraulic Area		Stroke	Tool Weight	Tool Dimensions (mm)					
Imperial	Metric	in	mm	TONF	KN	in <sup>2</sup>	mm <sup>2</sup>	mm	kg	a	b	c	d	e	f
1ST:1000	1ST:0024	1"	24	24.58	245	2.53	1634	30	3.2	82	25	218	120	144	61
1ST:1125	1ST:0027	1.1/8"	27	24.58	245					82	25	218	120	144	64
2ST:1250	2ST:0033	1.1/4"	33	38	379.2	3.92	2532	30	4.8	100	28	240	131	159	75
2ST:1375	2ST:0036	1.3/8"	36	38	379.2					100	28	240	131	159	78
3ST:1500	3ST:0039	1.1/2"	39	55.4	552	5.71	3688	30	6.2	112	35	249	133	166	84
3ST:1625	3ST:0042	1.5/8"	42	55.4	552					112	35	249	133	166	87
4ST:1750	4ST:0045	1.3/4"	45	75.6	753	7.79	5027	30	8.5	128	41	271	140	178	95.5
4ST:1875	4ST:0048	1.7/8"	48	75.6	753					128	41	271	140	178	98
5ST:2000	5ST:0052	2"	52	108	1076	11.12	7174	30	12.2	148	48	296	152	198	121
5ST:2250	5ST:0056	2.1/4"	56	108	1076					148	48	296	152	198	116
6ST:2500	6ST:0064	2.1/2"	64	165	1644	17	10968	30	19.2	176	58	335	168	224	135
6ST:2750	6ST:0072	2.3/4"	72	165	1644					176	58	335	168	224	141
7ST:3000	7ST:0076	3"	76	253.4	2525	26.1	16870	30	29	216	53	373	192	260	162
7ST:3500	7ST:0090	3.1/2"	90	253.4	2525					216	53	373	192	260	173

Note: Dimensions are subject to change as per customer requirement.

## ULTRA-HIGH PRESSURE ELECTRIC PUMP FOR TENSIONING APPLICATIONS



- ▶ Two stage piston pump, compact, robust and reliable
- ▶ 1.1 kw electric motor, powerful, big flow
- ▶ Safety and easy operating control line
- ▶ When pressure under the set pressure 1 bar / 14.5 psi, pressure switch start automatically and pressure will be raise to set value
- ▶ Single and double acting available, apply to various operation
- ▶ High performance radiator ensure continuous operation



Integral hydraulic system, compact and robust



Dual pistons, no gear pump, stable pressure

Model	Reservoir (L)	Motor (KW)	Supply *	Max. Working Pressure	Size (mm)	Control Line (m)	Output Flow (L/min)	Weight (kg)	Mode of Action
BEL-8	7.6	1.1	220V/50Hz/ single phase	2000 bar / 29000 psi	375X300X410	6	2@ 50 bar/725 psi 0.3@ 2000 bar/29000 psi	20	Single Acting
BEL-8D									Double Acting

\*Supply: Voltage and frequency can be demanded by customer





## AIR OPERATED HYDRAULIC POWER PACK FOR TENSIONERS



The air operated pumps are designed considering the safety, reliability and maximum operator comfort. All the pressure connections are facing away from operator.

Model No: BPL-100

Consumption of Free Air 800 litres per minute  
(28 standard cubic feet per minute)

Air Pressure Required 4 - 7 bar (60 - 100 psi)

Finish Pressure Gauge Dual Scale 0 - 2000 bar (0 - 29000 psi)

Working Pressure 1500 bar

## HAND PUMPS FOR BOLT TENSIONERS



Model No. BHP 15

Maximum Working Pressure :- 1600 Bar

Tanks Size : 1.8 / 2.4 Ltr.

The TRITORC 2-stage hand pumps come with standard pressure gauge; this gives the user precise and safe control over the work carried out. The gauge is directly mounted onto the pump and is well protected by the specially designed pump lever.

- Return connections on all pumps.
- Robust design
- Aluminium tank.
- Easy and simple maintenance



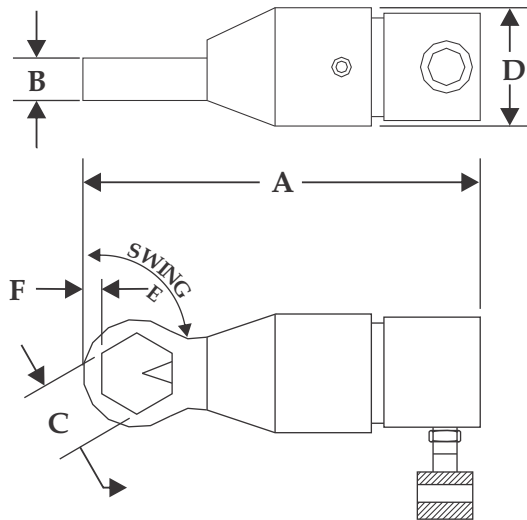

Model	Stud Diameter in (mm)	Nut A/F in(mm)	A in(mm)	B in(mm)	C in(mm)	D in(mm)	E	F in(mm)	Weight lbs(kg)
ASL 105	7/16"-7/8" (11-22)	5/8"-1 7/16" (16-36)	11" (271)	1.05 (38)	1.49" (38)	4.13" (105)	60°	0.39" (10)	20 (9)
ASL 200	7/8"-1 1/4" (22 - 31)	1 5/16" - 2" (33-50)	11.29" (287)	1.05" (38)	2.12" (54)	4.25" (108)	45°	0.51" (13)	21 (10)
ASL 204	1 1/4"-1 1/2" (32-38)	1 7/8"-2 3/8" (47-60)	15.16" (385)	2 1/4" (57)	2.52" (64)	6.45" (164)	30°	0.55" (14)	71 (32)
ASL 210	1 3/8"-1 3/4" (39-44)	2 1/16"-2 3/4" (52-70)	16.10" (398)	2 1/4" (57)	2.87" (73)	6.45" (164)	30°	0.70" (18)	72 (33)
ASL 308	1.3/4"-2.1/4" (45-57)	2.5/8"-3.1/2" (70-89)	17.75" (460)	3" (77.8)	3.89" (99)	8.42" (214)	30°	0.75" (19)	158 (72)
ASL 314	2"-2.1/2" (50-64)	3.1/8"-3.7/8" (79-98)	18" (488)	3.12" (79.4)	4.25" (108)	8.42" (214)	30°	0.86" (22.2)	163 (74)
ASL 404	2.1/2"-2.3/4" (64-70)	3.3/4"-4.1/4" (95-108)	22.75" (579)	3.75" (95.3)	4.64" (118)	9.88" (251)	60°	1.14" (28.6)	251 (114)
ASL 500	3"-3.1/4" (76-83)	4.1/2"-5" (114-127)	23" (590)	4.12" (104.8)	5.39" (137)	9.88" (251)	60°	1.14" (28.6)	256 (116)
ASL 506	3.1/4"-3.1/2" (83-89)	4.7/8"-5.3/8" (124-136)	23.5" (598)	4.12" (104.8)	5.86" (149)	9.88" (251)	60°	1.14" (28.6)	262 (119)

## TRITORC Nut Splitter is supplied Complete with:

- ▶ Hydraulic Cylinder
- ▶ Housing
- ▶ Chisel
- ▶ Set of Allen Keys
- ▶ Spacer Set
- ▶ Packed in a Rugged Steel Tool Box.

## Application

- ▶ Designed for Operator Comfort
- ▶ Removes Corroded Nuts Faster
- ▶ Removes Frozen Nuts Safely
- ▶ Fits Tight Spaces
- ▶ Cuts through the Hardest Nuts

# TRITORC LIGHT WEIGHT NUT SPLITTER

TRITORC Light Weight Hydraulic Nut Splitters are used in applications that involve corrosion; it can be used to remove corroded or frozen nuts fast and safely. The light weight option helps the user to apply the product to lower sized bolts.

TRITORC offers Light Weight Nut splitters for a range of Hex size 0.37" to 2.95". Our product is designed for operator comfort that fits tight spaces and it cuts through the hardest of nuts.

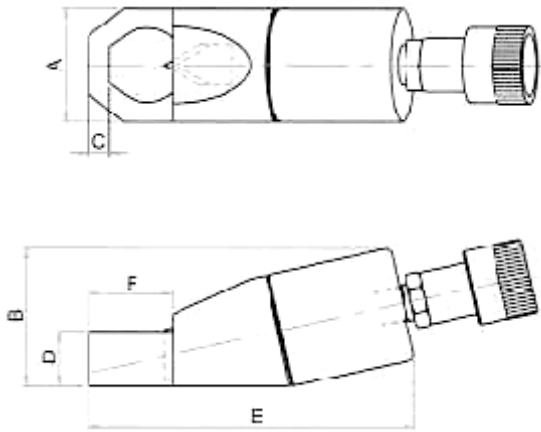

Model	Hex Size in (mm)	Thread Size in(mm)	A in(mm)	B in(mm)	C in(mm)	D in(mm)	E in(mm)	F in(mm)	Weight lbs(kg)	Replacement Chisel Model Nos.
STANDARD										
NSL-5	0.37"-0.75" (10-19)	M6-M12	1.57" (40)	2.04" (52)	0.31" (8)	0.79" (20)	5.11" (130)	1.18" (30)	2 (1)	TNSC - 5
NSL-10	0.75"-0.94" (19-24)	M12-M16	2.12" (54)	2.64" (67)	0.47" (12)	0.94" (24)	6.41" (163)	1.41" (41)	4 (2)	TNSC - 10
NSL-15	0.94"-1.26" (24-32)	M16-M22	2.52" (64)	3.11" (79)	0.51" (13)	1.18" (30)	7.36" (187)	2.04" (52)	6 (3)	TNSC - 15
NSL-20	1.26"-1.61" (32-41)	M22-M27	3.07" (78)	3.70" (94)	0.78" (20)	1.46" (37)	8.62" (219)	2.72" (69)	10 (4.5)	TNSC - 20
NSL-35	1.61"-1.97" (41-50)	M27-M33	3.74" (95)	4.45" (113)	0.83" (21)	1.77" (45)	10.43" (265)	3.07" (78)	21 (9.6)	TNSC - 35
NSL-50	1.97"-2.36" (50-60)	M33-M39	4.17" (106)	5.04" (128)	0.98" (25)	2.12" (54)	11.69" (297)	3.58" (91)	29 (13)	TNSC - 50
NSL-90	2.36"-2.95" (60-75)	M39-M48	6.14" (156)	7.28" (185)	1.06" (27)	2.95" (75)	14.05" (357)	4.33" (110)	75 (34)	TNSC - 90

- ▶ Higher capacity and customized solutions on request.
- ▶ Specifications are subject to change due to continual improvement.

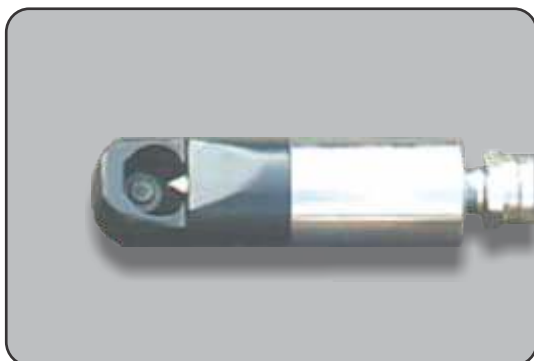

## Application

- ▶ The fast, sure and safe method to cut and remove seized nuts.
- ▶ Compact and ergonomic angled head design.
- ▶ Heavy duty cutting tool, can be re-ground.

# TRITORC FLANGE SPREADERS

TRITORC Hydraulic Flange Spreaders are used for safe opening of pipe flanges available in capacities of 5 tons and 10 tons. The versatility of both models enables the user to open flanges up to 92mm thick.

Hydraulic flange spreaders can be operated individually or as a pair when opening large diameter flanges. It can be operated with a standard Hydraulic Hand Pump with a connecting hose supplied in a handy steel storage case.

Specification	PS- 10H Hydraulic		PS- 10M Manual	
	Imperial	Metric	Imperial	Metric
Weight	15.5 lbs	7.0 kg	17.0 lbs	7.7 kg
Length	13.25"	336mm	14"	355mm
Width of Jaws	4.5"	114mm	4.5"	114mm
Width of Body	4"	101mm	4"	101mm
Jaws Closed	0.9"	2.3mm	0.9"	2.3mm
Jaws Open	3"	76.2mm	3"	76.2mm
Jaw Penetration	1.5"	38.1mm	1.5"	38.1mm
Rated Force	10,000lbs	4.5 Tons	10,000 lbs	4.5 Tons



**PS10K Hydraulic Model**



**PS10K Manual Model**

## HYDRAULIC FLANGE SPREADERS

- ▶ Hydraulic Flange Spreaders are used for safe opening of pipe flanges.
- ▶ Available in capacities of 5 to 10 tons. The versatility of both models enables the user to open flanges upto 92mm.
- ▶ Operated with a standard hydraulic hand pump and connecting hose and supplied in a handy steel storage case, Hydraulic Flange Spreaders can be operated individually, or as a pair when opening large diameter flanges.
- ▶ Hydraulic Flange Spreaders take just minutes to open the toughest flanges without the risks of sparks caused by hammer blows and chisels.

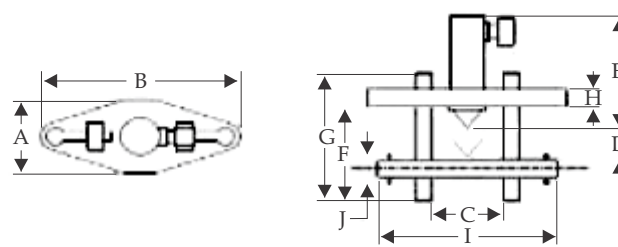

(All Dimensions in MM)

Model No.	A	B	C		D	E	F	G	H	I	J
			MIN	MAX							
FF-50	77	210	61	157	10	192	69	131	25	205	81
FF-100	110	290	61	226	30	165	89	180	38	274	31

Model No.	Capacity	Stroke	Oil Capacity	Max. Flange Thickness	Flange Diameter	Stud Size	Standard Model No. Wedge	Optional Wedge
	tons	mm	cm3	mm	mm (inch)	mm	mm	mm
FF-50	5	39	25	2x58	1150mm(45")	19-29	3 - 29	30 - 56
FF-100	10	55	78	2 x 93	1900mm(75")	32 - 41	3 - 29	30 - 56

# TRITORC FLANGE SPREADERS

## HYDRAULIC VERTICAL LIFTING WEDGE HVWL-10

TRITORC Hydraulic Vertical Lifting Wedge HVWL-10 has been developed as an easy to use or a cost effective way to find solutions to heavy lifting where minimum clearance is available. It

will lift objects vertically where an access gap of 3/8" (9.5mm) or more is available. The HVWL-10 will lift an object fast, with a secure and fast lifting force of 16 Tons per tool.



### Special Features :

- ▶ Access gap of only 3/8" (9.5mm) needed.
- ▶ 3/4" (19.0mm) of vertical lift available from each step.
- ▶ Max. height of 50mm on 4th step.
- ▶ Automatic spring return retraction.
- ▶ Interlocking first step ensures safe hold.
- ▶ No Slippage due to locking.
- ▶ Will lift in a straight vertical place.

### Kit Options



#### MINI KIT

- 1 x Hydraulic Vertical Lifting Wedge Assembly
- 1 x Safety Block
- 1 x Stepped Block
- 1 x Instruction Manual



#### STANDARD KIT

- 1 x Hydraulic Vertical Lifting Wedge Assembly
- 1 x 10,000 psi (700 Bar) Two Stage Hydraulic Hand Pump
- 1 x 10,000 psi (700 Bar) Hydraulic Hose Length 6 feet
- 1 x Safety Block
- 1 x Stepped Block
- 1 x Instruction Manual
- 1 x Carry Case

## HYDRAULIC SPREADING WEDGE HSWL-10

The spreading Wedge has been developed as the simple cost effective solution for flange spreading.



### Special Features :

- ▶ Only requires an access gap of 1/4" (6 mm)
- ▶ Robust Light weight Tool-Just 7.2 kg (16 lbs)
- ▶ 10,000 psi (700 Bar) generates 14.0 Tons spreading force.
- ▶ Automatic Spring Return.
- ▶ Locking at first step ensures on slippage increased safety.

#### MINI KIT

- 1 x Hydraulic Spreading Wedge Assembly
- 1 x Safety Block
- 1 x Instruction Manual
- 1 x Carry Case

#### STANDARD KIT

- 1 x Hydraulic Spreading Wedge Assembly
- 1 x 10,000 psi (700 Bar) Two Stage Hydraulic Hand Pump
- 1 x 10,000 psi (700 Bar) Hydraulic Hoses
- 1 x Safety Block
- 1 x Instruction Manual
- 1 x Carry Case
- Gross Weight: 17 kg

#### STEPPED BLOCK ACCESSORY

- 2 x Stepped Blocks
- 2 x CSK M6 x 12mm
- Countersunk Screws

#### MAXI KIT

- 2 x Hydraulic Spreading Wedge Assembly
- 1 x 10,000 psi (700 Bar)
- Two Stage Hydraulic Hand Pump
- 2 x 10,000 psi (700 Bar) Hydraulic Hoses
- 2 x Safety Block
- 1 x Instruction Manual
- 1 x Carry Case
- 1 x 10,000 psi Twin Valve manifold
- Gross Weight: 28 kg



# NON SPARKING SPANNERS

## Non-Sparking Hand / Impact Sockets



	Socket A/F sizes (mm/inch)
1/4"	4, 4.5, 5.5, 6, 7, 8, 9, 10, 11, 12, 13, 14, 15, 16, 17, 18, 19 5/32, 3/16, 7/32, 1/4, 9/32, 5/16, 11/32, 3/8, 7/16, 1/2
3/8"	5/16, 3/8, 7/16, 1/2, 9/16, 5/8, 11/16, 3/4, 13/16, 7/8, 15/16 5/16, 3/8, 7/16, 1/2, 9/16, 5/8, 11/16, 3/4, 13/16, 7/8, 15/16
1/2"	6, 7, 8, 9, 10, 11, 12, 13, 14, 15, 16, 17, 18, 19, 20, 21, 22, 23, 24, 25, 26, 27, 28, 29, 30, 32 5/16, 3/8, 7/16, 1/2, 9/16, 5/8, 11/16, 3/4, 13/16, 7/8, 15/16, 1, 1-1/16, 1-1/4, 1-7/16
3/4"	17, 19, 21, 22, 23, 24, 26, 27, 28, 29, 30, 31, 32, 34, 36, 38, 41, 46, 50 3/16, 13/16, 7/8, 15/16, 1, 1-1/16, 1-1/8, 1-3/16, 1-1/4, 1-5/16, 1-3/8, 1-7/16, 1-1/2, 1-5/8, 1-3/4, 1-13/16, 1-7/8, 2
1"	22, 24, 25, 26, 27, 28, 29, 30, 31, 32, 34, 36, 38, 41, 46, 50, 55, 60, 65, 70, 75, 80 1-1/16, 1-1/8, 1-1/4, 1-3/8, 1-1/2, 1-5/8, 1-7/8, 2, 2-1/4, 2-1/2, 2-3/4, 3

## Non-sparking Slugging Wrenches Box Type



A/F Sizes (mm/inch)
17, 19, 20, 22, 24, 27, 30, 31, 32, 36, 38, 41, 46, 50, 52, 55, 60, 65, 70, 75, 80, 85, 90, 95, 100, 110, 120, 130, 140, 150
11/16, 11/16, 3/4, 7/8, 1, 1-1/16, 1-1/8, 1-3/16, 1-1/4, 1-3/8, 1-13/32, 1-1/2, 1-5/8, 1-3/4, 1-13/16, 2, 2-1/16, 2-3/16, 2-13/64, 2-5/16, 2-3/8, 2-1/2, 2-9/16, 2-5/8, 2-3/4, 2-15/16, 3, 3-1/16, 3-1/8, 3-3/8, 3-9/16, 3-3/4, 3-15/16, 4-1/8

## Non-sparking Slugging Wrenches Open Type



A/F Sizes (mm/inch)
17, 19, 20, 22, 24, 27, 30, 31, 32, 36, 38, 41, 46, 50, 52, 55, 60, 65, 70, 75, 80, 85, 90, 95, 100, 110, 120, 130, 140, 150
11/16, 3/4, 7/8, 1, 1-1/16, 1-1/8, 1-3/16, 1-1/4, 1-3/8, 1-13/32, 1-1/2, 1-5/8, 1-3/4, 1-13/16, 2, 2-1/16, 2-3/16, 2-13/64, 2-5/16, 2-3/8, 2-1/2, 2-9/16, 2-5/8, 2-3/4, 2-15/16, 3, 3-1/16, 3-1/8, 3-3/8, 3-9/16, 3-3/4, 3-15/16, 4-1/8

## Non-Sparking Flat / Half Round Files



Sizes (inches)
6, 8, 10, 12, 14, 16

## Non-sparking Combination Spanners



## Non-Sparking Adjustable Wrenches & Pipe Wrenches



L (mm)	L (inch)
150, 200, 250, 300, 350, 375, 450, 600	6, 8, 10, 12, 14, 15, 18, 24

A/F Sizes (mm/inch)
6, 7, 8, 9, 10, 11, 12, 13, 14, 15, 16, 17, 18, 19, 20, 21, 22, 23, 24, 25, 26, 27, 28, 29, 30, 31, 32, 33, 34, 35, 36, 37, 38, 39, 40, 41, 42, 43, 44, 45, 46, 47, 48, 49, 50, 51, 52, 53, 54, 55, 56, 57, 58, 59, 60, 61, 62, 63, 64, 65, 66, 67, 68, 69, 70, 71, 72, 73, 74, 75, 76, 77, 78, 79, 80, 81, 82, 83, 84, 85, 86, 87, 88, 89, 90
1/4, 5/16, 3/8, 7/16, 1/2, 9/16, 19/32, 5/8, 11/16, 3/4, 13/16, 7/8, 15/16, 1, 1-1/16, 1-1/8, 1-3/16, 1-1/4, 1-5/16, 1-3/8

# NON SPARKING TOOLS

## Non-Sparking Sledge Hammers



### Weight (gms)

450, 1000, 1400, 1500, 1800, 2000, 2200, 2500, 2700, 3000, 3600, 4000, 4500, 5000, 5400, 6400, 7200, 8000, 8200, 9100, 9900

## Non-Sparking Chisels



### Sizes (OAL mm)

160, 200, 250, 300, 400, 500

## Non-sparking Ball Pen Hammers



### Weight (gms)

230, 340, 450, 680, 910, 1130

## Non-Sparking Slotted Screwdrivers



### L 1 (inch)

2, 3, 4, 5, 6, 8, 10, 12, 14, 16, 18

## Non-Sparking Double Ended Open Type Spanners



### A / F Sizes S<sub>1</sub>xS<sub>2</sub> (mm / inch)

5.5x7, 6x7, 6x8, 7x9, 8x9, 8x10, 9x10, 9x11, 10x11, 10x12, 10x14, 11x13, 12x13, 12x14, 13x17, 14x15, 14x17, 16x17, 16x18, 17x19, 17x21, 17x22, 18x19, 19x21, 19x22, 19x24, 20x22, 21x23, 21x26, 22x24, 22x27, 23x26, 24x26, 24x27, 24x30, 25x28, 26x29, 26x32, 27x29, 27x30, 27x32, 29x32, 30x32, 30x36, 32x34, 32x36, 34x36, 36x38, 36x41, 38x40, 41x46, 46x50, 50x55, 50x60, 55x60, 60x65, 65x70

1/4x5/16, 5/16x3/8, 3/8x7/16, 3/8x1/2, 7/16x1/2, 1/2x9/16, 9/16x5/8, 5/8x11/16, 5/8x3/4, 11/16x3/4, 3/4x13/16, 3/4x7/8, 13/16x7/8, 7/8x15/16, 15/16x1, 1x1-1/16, 1-1/16x1-1/8, 1-1/8x1-3/16, 1-3/16x1-1/4, 1-1/4x1-5/16, 1-5/16x1-3/8, 1-3/8x1-7/16, 1-7/16x1-5/8, 1-1/2x1-9/16, 1-5/8x1-13/16, 1-13/16x2, 2x2-3/16, 2x2-3/8, 2-3/16x2-3/8, 2-3/8x2-9/16

## Non-Sparking Pliers



L (inch)	L (mm)	K (mm)
6	152	8
8	203	13

## Non-sparking Double Ended Ring Type Spanners



### A / F Sizes S<sub>1</sub>xS<sub>2</sub> (mm / inch)

5.5x7, 6x7, 6x8, 7x9, 8x9, 8x10, 9x10, 9x11, 10x11, 10x12, 10x14, 11x13, 12x13, 12x14, 13x17, 14x15, 14x17, 16x17, 16x18, 17x19, 17x21, 17x22, 18x19, 19x21, 19x22, 19x24, 20x22, 21x23, 21x26, 22x24, 22x27, 23x26, 24x26, 24x27, 24x30, 25x28, 26x29, 26x32, 27x29, 27x30, 27x32, 29x32, 30x32, 30x36, 32x34, 32x36, 34x36, 36x38, 36x41, 38x40, 41x46, 46x50, 50x55, 50x60, 55x60, 60x65, 65x70

1 / 4x5 / 16, 5 / 16x3 / 8, 3 / 8x7 / 16, 3 / 8x1 / 2, 7 / 16x1 / 2, 1 / 2x9 / 16, 9 / 16x5 / 8, 5 / 8x 11 / 16, 5 / 8x3 / 4, 11 / 16x3 / 4, 3 / 4x13 / 16, 3 / 4x7 / 8, 13 / 16x7 / 8, 7 / 8x15 / 16, 15 / 16x1, 1x1 -1 / 16, 1-1 / 16x1-1/8, 1-1 / 8x1-3/16, 1-3 / 16x1-1 / 4, 1-1 / 4x-5 / 16, 1-5 / 16x1-3 / 8, 1-3 / 8x1- 7 / 16, 1-7 / 16x1-5 / 8, 1-1 / 2x1-9 / 16, 1-5 / 8x1-13 / 16, 1-13 / 16x2, 2x2-3 / 16, 2x2 3 / 8, 2-3 / 16x2-3 / 8, 2-3 / 8x2-9 / 16

Material	Aluminium - Bronze					Copper-beryllium			
	Cu	Al	Ni	Fe	Mn	Be	Ni	Co	Cu
Analysis	Rest	9-12	2-6	1-4	0-1.8	1.5-2	0.1-0.6	0.1-0.6	Rest
%									

**Note:** We have also developed the ACETILEX Alloy tools (Less than 70% copper), 100% safe to be used in Acetylene environments

# POWERPACK FOR CYLINDERS

Reservoir Capacity: 28 - 55 litres  
 Flow at Rated Pressure: 1 - 2.21/min  
 Motor Size: 1.5 - 3 kw  
 Max. Operating Pressure: 700 bar



Model No.	Oil Flow		Pressure (bar)		Power (kw)	Oil Capacity (L)	Input Power*	Weight (kg)	Dimensions (mm)
	High Pressure	Low Pressure	High Pressure	Low Pressure					
	(l/min)	(l/min)	(bar)	(bar)					
EL 10	1	6.3	700	70	1.5	28	220V-440V 3Ph/50Hz	50	565*385*620
	1	7.5	700	70	1.5	28	220V-480V 3Ph/60Hz	50	565*385*620
EL 15	1.5	7	700	70	2.2	28	220V-440V 3Ph/50Hz	55	565*385*620
	1.5	8	700	70	2.2	28	220V-480V 3Ph/60Hz	55	565*385*620
EL 25	2.2	9.3	700	70	3	55	220V-440V 3Ph/50Hz	74	605*525*790
	2.2	8.6	700	70	3	55	200V-480V 3Ph/60Hz	74	605*525*790

# HAND PUMP FOR CYLINDERS

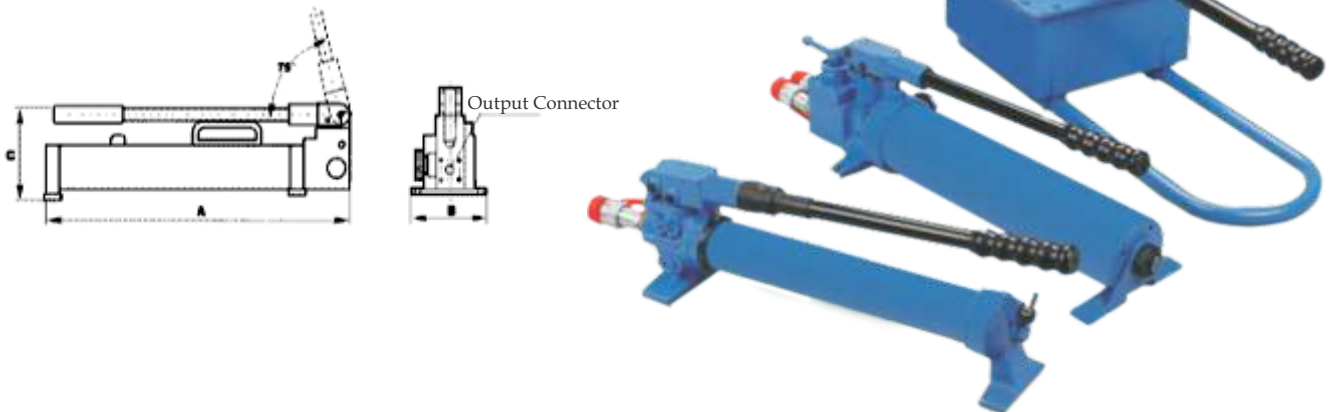

Pump Type	Usable Oil Capacity (cm <sup>3</sup> )	Model Number	Pressure Rating (Bar)		Output Oil Volume Each Stroke (cm <sup>3</sup> )		Handle Force (N)	Dimensions (mm)			Output Adapter	Weight (Kg)
			1st Stage	2st Stage	1st Stage	2st Stage		A	B	C		
			Double Speed	655	HH 7 - 0.7	25		700	15	2.6		
1440	HH 7-1	25		700	32	2.5	577	120	170	6.3		
2200	HH 7-2	25		700	16	2.5	539	146	170	8		
3240	HH 7-3	25		700	32	2.5	582	200	170	10		
5860	HH 7-4	25		700	32	2.5	667	250	172	14.5		
7500	HH 7-8	14		700	126	4.8	742	308	270	27		
1440	HH 16-1	15		1600	32	2.5	375	577	120	170	G 1/4"	6.3
3240	HH 16-3	15		1600	32	2.5		577	140	190		10

TRITORC cylinders operate with a maximum pressure of 700 Bar. With Single and Double acting ranges TRITORC cylinders show versatility in operational requirements and fulfill the needs of the user.

All Single Acting Cylinders are spring return and Double Acting Cylinders are oil return.



## Single-Acting Hollow Hydraulic Cylinder



Capacity: 13-95 ton  
Stroke: 42-155 mm  
Max. Pressure: 700 bar

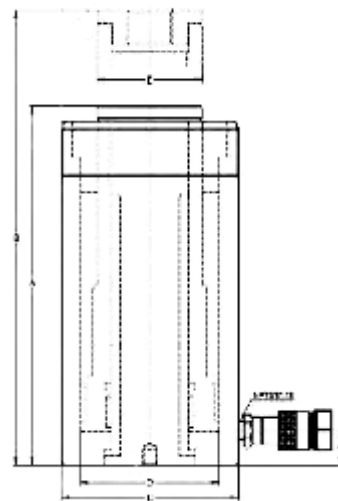

Cylinder Capacity	Stroke	Model Number	Oil Capacity	Collapsed Height	Extend Height	Outside Dia.	Cylinder Bore Dia.	Plunger Dia. (Thread)	Weight
				A	B	C	D	E	
ton (kN)	(mm)		(cm <sup>3</sup> )	(mm)	(mm)	(mm)	(mm)	(mm)	(Kg)
13 (125)	42	SAHH 130-42	76	130	172	76	55	35.5	3.4
	76	SAHH 130-76	138	184	260	76	55	35.5	5.2
20 (215)	49	SAHH 200-49	174	162	211	101	77	54.5	8.2
	155	SAHH 200-155	550	306	461	101	77	54.5	15
30 (326)	64	SAHH 300-64	307	180	244	115	90	64.5	11.5
	155	SAHH 300-155	744	330	485	115	90	64.5	21.5
60 (576)	76	SAHH 600-76	640	247	323	159	125	94.5	28.2
	153	SAHH 600-153	1278	323	476	159	125	94.5	35.5
95 (931)	76	SAHH 1000-76	1028	254	330	212	165	125	63.5



# Single Acting Hydraulic Cylinder



Capacity: 5-95 ton  
Stroke: 25-362 mm  
Max. Pressure: 700 bar

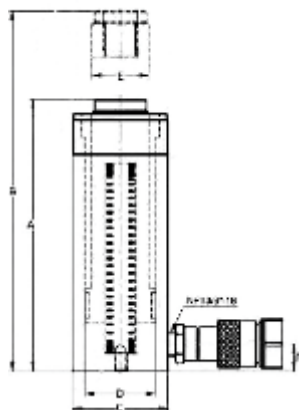

Cylinder Capacity	Stroke	Model Number	Oil Capacity	Collapsed Height	Extended Height	Outside Dia.	Cylinder Bore Dia.	Plunger Dia.	Weight
			(cm <sup>3</sup> )	A	B	C	D	E	
ton	(mm)			(mm)	(mm)	(mm)	(mm)	(mm)	(Kg)
5 (45)	25	SAH 5-25	18	110	135	40	30	25	1
	76	SAH 5-76	54	165	241	40	30	25	1.6
	127	SAH 5-127	90	215	342	40	30	25	2
	177	SAH 5-177	125	273	450	40	30	25	2.6
	232	SAH 5-232	164	323	555	40	30	25	3.1
10 (101)	54	SAH 10-54	86	121	175	59	45	35	2.3
	105	SAH 10-105	167	171	276	59	45	35	3
	156	SAH 10-156	248	247	403	59	45	35	4.1
	203	SAH 10-203	323	298	501	59	45	35	5.8
	257	SAH 10-257	409	349	606	59	45	35	6.6
	304	SAH 10-304	483	400	707	59	45	35	7.5
15 (142)	356	SAH 10-356	566	450	806	59	45	35	8.3
	25	SAH 15-25	53	124	149	70	52	42	3.5
	51	SAH 15-51	108	149	200	70	52	42	4
	101	SAH 15-101	214	200	301	70	52	42	5
	152	SAH 15-152	323	271	423	70	52	42	7
	203	SAH 15-203	431	322	525	70	52	42	8
	254	SAH 15-254	539	373	627	70	52	42	9
	305	SAH 15-305	647	423	728	70	52	42	10
25 (232)	356	SAH 15-356	756	474	830	70	52	42	11
	26	SAH 25-26	86	139	165	85	65	56	6
	50	SAH 25-50	166	165	215	85	65	56	7
	102	SAH 25-102	338	215	317	85	65	56	8
	158	SAH 25-158	524	273	431	85	65	56	10
	210	SAH 25-210	696	323	533	85	65	56	12
	261	SAH 25-261	866	374	635	85	65	56	14
	311	SAH 25-311	1031	425	736	85	65	56	15
30 (295)	362	SAH 25-362	1201	476	838	85	65	56	17
	50	SAH 30-50	209	228	278	101	73	60	13
	100	SAH 30-100	418	278	378	101	73	60	16
	209	SAH 30-209	874	387	596	101	73	60	19
50 (498)	300	SAH 30-300	1255	478	778	101	73	60	27
	51	SAH 50-51	361	176	206	127	95	80	19
	101	SAH 50-101	716	227	307	127	95	80	19
	159	SAH 50-159	1126	282	422	127	95	80	23
75 (718)	337	SAH 50-337	2388	460	797	127	95	80	37
	156	SAH 75-156	1620	285	441	150	115	100	33
95 (933)	333	SAH 75-333	3457	492	825	150	115	100	54
	168	SAH 100-168	2229	357	525	177	130	112	59
95 (933)	260	SAH 100-260	3449	449	709	177	130	112	72

# Single-Acting High Tonnage Hydraulic Cylinder



Capacity: 50-800 ton  
Stroke: 50-300 mm  
Max. Pressure: 700 bar

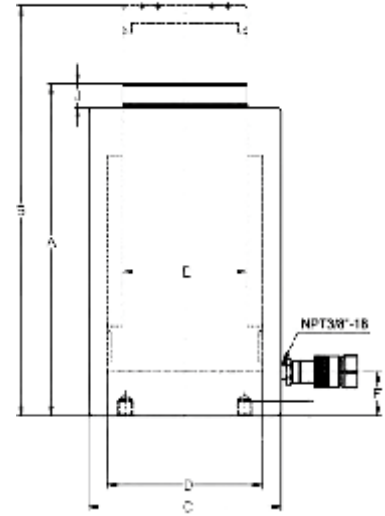
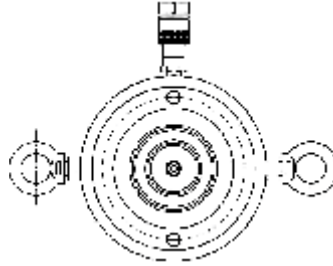

Cylinder Capacity	Stroke	Model Number	Cylinder Effective Area	Oil Capacity	Collapsed Height	Extend Height	Outside Dia.	Cylinder Bore Dia.	Plunger Dia.	Base to Advance Port	Weight
					A	B	C	D	E	F	
ton	(mm)		(cm <sup>2</sup> )	(cm <sup>3</sup> )	(mm)	(mm)	(mm)	(mm)	(mm)	(mm)	(Kg)
50	50	STH 50-50	78.5	392	188	238	140	100	70	41	21.5
	100	STH 50-100	78.5	784	238	338	140	100	70	41	26
	150	STH 50-150	78.5	1176	288	438	140	100	70	41	31
	200	STH 50-200	78.5	1568	338	538	140	100	70	41	35
	300	STH 50-300	78.5	2352	438	738	140	100	70	41	44
100	50	STH 100-50	153.9	770	216	266	180	140	100	54	42
	100	STH 100-100	153.9	1540	266	366	180	140	100	54	49
	150	STH 100-150	153.9	2310	316	466	180	140	100	54	56
	200	STH 100-200	153.9	3080	366	566	180	140	100	54	63
	300	STH 100-300	153.9	4620	466	766	180	140	100	54	70
150	50	STH 150-50	201	1005	224	274	210	160	112	58	44
	100	STH 150-100	201	2010	274	374	210	160	112	58	57
	150	STH 150-150	201	3015	324	474	210	160	112	58	70
	200	STH 150-200	201	4020	374	574	210	160	112	58	83
	300	STH 150-300	201	6030	474	774	210	160	112	58	109
200	50	STH 200-50	314	1570	246	296	250	200	150	64	84
	150	STH 200-150	314	4712	346	496	250	200	150	64	118
	300	STH 200-300	314	9423	496	796	250	200	150	64	152
320	50	STH 300-50	490.6	2453	277	327	315	250	180	74	155
	150	STH 300-150	490.6	7359	377	527	315	250	180	74	195
	300	STH 300-300	490.6	14718	527	827	315	250	180	74	255
400	50	STH 400-50	572.3	2861	305	355	355	270	220	83	240
	150	STH 400-150	572.3	8583	405	555	355	270	220	83	310
	300	STH 400-300	572.3	17169	555	855	355	270	220	83	415
500	50	STH 500-50	803.8	4019	325	375	395	320	250	93	285
	150	STH 500-150	803.8	12057	425	575	395	320	250	93	353
	300	STH 500-300	803.8	24114	575	875	395	320	250	93	455
630	50	STH 600-50	1017.4	5087	386	436	450	360	280	115	487
	150	STH 600-150	1017.4	15261	486	636	450	360	280	115	579
	300	STH 600-300	1017.4	30522	636	936	450	360	280	115	717
800	50	STH 800-50	1256	6280	427	477	550	400	320	113	712
	150	STH 800-150	1256	18840	527	677	550	400	320	113	860
	300	STH 800-300	1256	37698	677	977	550	400	320	113	1082

# Single-Acting Low Profile Lock-nut Hydraulic Cylinder



Capacity: 60-520 ton  
Stroke: 45-50 mm  
Max. Pressure: 700 bar

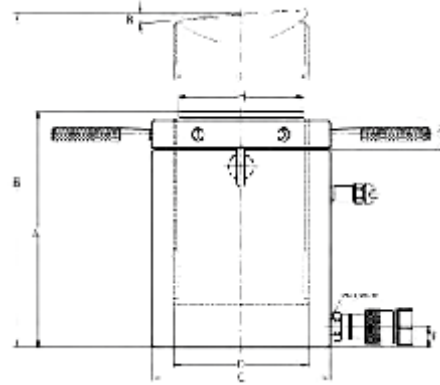

Cylinder Capacity ton	Stroke (mm)	Model Number	Oil Capacity	Collapsed Height	Extended Height	Outside Dia.	Cylinder Bore Dia.	Plunger Dia. (Thread)	Base to Advance port	Saddle Dia.	Saddle Protrusion from Plgr.	Saddle Max. Tilt Angle	Plunger Dia.	Weight (Kg)
				A (mm)	B (mm)	C (mm)	D (mm)	E (mm)	F (mm)	H (mm)	J (mm)	R (mm)	S (mm)	
60 (606)	50	SLLH 60-50	432	125	175	140	106	Tr104x4	19	96	6	5	28	15
100 (1027)	50	SLLH 100-50	734	137	187	180	137	Tr136x6	21	126	8	5	31	27
160 (1619)	45	SLLH 160-45	1040	148	193	224	172	Tr171x6	27	160	9	5	40	45.5
200 (1999)	45	SLLH 200-45	1285	155	200	245	190.7	Tr190x6	30	180	10	5	43	57
260 (2567)	45	SLLH 250-45	1650	159	204	275	216	Tr215x6	32	200	11	5	44	74
400 (3916)	45	SLLH 400-45	2517	178	223	350	270	Tr266x6	41	251	11	4	55	134
520 (5114)	45	SLLH 500-45	3287	192	237	400	305	Tr304x6	48	289	10	3	62	188

# Single-Acting Low Profile Hydraulic Cylinder



Capacity: 10-150 ton  
Stroke: 11-80 mm  
Max. Pressure: 700 bar

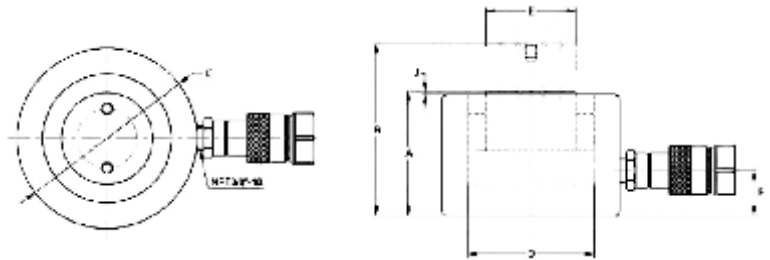

Cylinder Capacity ton (kN)	Stroke (mm)	Model Number	Oil Capacity (cm <sup>3</sup> )	Collapsed Height	Extend Height	Outside Dia.	Cylinder Bore Dia.	Plunger Dia. (Thread)	Base to Advance port	Saddle Protrusion from Plgr.	Saddle Max. Tilt Angle	Plunger to Mounting Hole	Weight (Kg)
				A (mm)	B (mm)	C (mm)	D (mm)	E (mm)	F (mm)	J (mm)	M (mm)	N (*)	
10 (101)	38	SLH 10-38	60	88	126	78	45	35	23	2	-	-	4
20 (201)	45	SLH 20-45	140	97	142	96	63	50	23	2	-	-	6.9
30 (295)	64	SLH 30-64	290	117	181	109	76	60	23	2	-	-	9.8
50 (435)	60	SLH 50-60	471	120	180	233	200	80	24	2	-	-	13.3
75 (718)	50	SLH 75-50	584	116	166	157	122	100	21	2	-	-	19
100 (887)	57	SLH 100-57	877	141	198	176	140	112	31	2	-	-	24.5
150 (1386)	51	SLH 150-51	1184	141	192	215	172	145	28	2	-	-	42
150 (1386)	80	SLH 150-80	1860	170	250	215	172	145	28	2	-	-	50

# Single-Acting Low Flat Hydraulic Cylinder



Capacity: 10-150 ton  
Stroke: 11-80 mm  
Max. Pressure: 700 bar

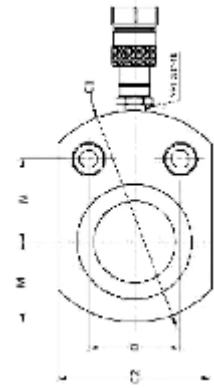
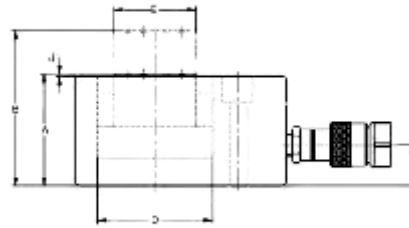

Cylinder Capacity ton (kN)	Stroke (mm)	Model Number	Oil Capacity (cm <sup>3</sup> )	Collapsed Height	Extend Height	Outside Dia.	Cylinder Bore Dia.	Plunger Dia. (Thread)	Base to Advance port	Saddle Protrusion from Plgr.	Saddle Max. Tilt Angle	Plunger to Mounting Hole	Weight (Kg)
				A (mm)	B (mm)	C (mm)	D (mm)	E (mm)	F (mm)	J (mm)	M (mm)	N (*)	
10 (101)	11	SLFH 10-11	18	44	55	83x60	45	35	23	1	31.5	34	1.4
20 (201)	12	SLFH 20-12	37	52	64	102x80	63	50	23	1	41	39	2.2
30 (295)	13	SLFH 30-13	59	58	71	117x97	76	60	23	1	48.5	47	4.2
50 (435)	16	SLFH 50-16	125	67	83	150x125	100	80	23	1	63	60	7.4
75 (718)	16	SLFH 75-16	187	79	96	177x152	122	100	23	1	76.5	73	12.7
100 (887)	16	SLFH 100-16	246	87	103	203x179	140	112	23	1	89.5	84	15.5
150 (1386)	16	SLFH 150-16	371	95	111	236x212	172	145	23	1	106	92	28.7

# Double-Acting Hollow Hydraulic Cylinder



Capacity: 30-145 ton  
Stroke: 38-258 mm  
Max. Pressure: 700 bar

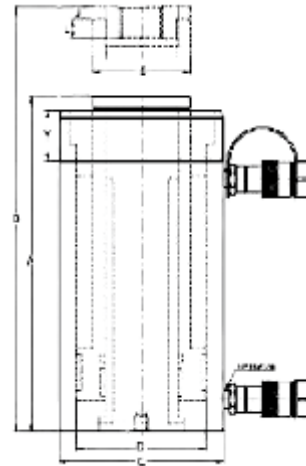

Cylinder Capacity ton (kN)	Stroke (mm)	Model Number	Max. Cylinder Capacity		Oil Capacity		Collapsed Height	Extend Height	Outside Dia.	Cylinder Bore Dia.	Plunger Dia. (Thread)	Weight (Kg)
			Advance (kN)	Retract (kN)	Advance (cm <sup>3</sup> )	Retract (cm <sup>3</sup> )	A (mm)	B (mm)	C (mm)	D (mm)	E (mm)	
30	178	DHH 300-178	326	210	855	550	330	508	115	90	64.5	21
	258	DHH 300-258	326	210	1240	798	431	689	115	90	64.5	27
60	89	DHH 600-89	576	360	749	468	247	336	159	125	94.5	28
	166	DHH 600-166	576	360	1398	873	323	489	159	125	94.5	35
	257	DHH 600-257	576	360	2146	1352	438	695	159	125	94.5	45
95	38	DHH 1000-38	931	627	517	345	165	203	212	165	125	33
	76	DHH 1000-76	931	627	1028	692	254	330	212	165	125	61
	153	DHH 1000-153	931	627	2070	1394	342	495	212	165	125	79
	257	DHH 1000-257	931	627	3477	2341	460	717	212	165	125	106
145	203	DHH 1500-203	1429	749	4191	2198	359	562	247	190.5	150	111



# Double Acting High Tonnage Hydraulic Cylinder



Capacity: 50-800 ton  
Stroke: 50-300 mm  
Max. Pressure: 700 bar

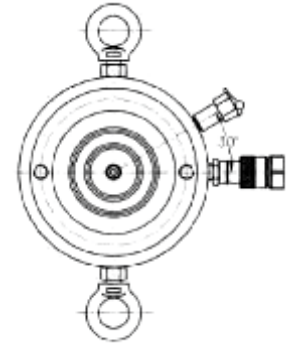
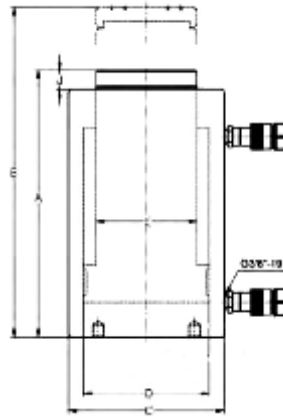

Cylinder Capacity	Stroke	Model Number	Max. Cylinder Capacity		Oil Capacity		Collapsed Height	Extended Height	Outside Dia.	Cylinder Bore Dia.	Plunger Dia.	Weight
			Advance	Retract	Advance	Retract	A	B	C	D	E	
ton	(mm)		(KN)		(cm <sup>3</sup> )		(mm)	(mm)	(mm)	(mm)	(mm)	(Kg)
50	50	DHT50-50	500	255	392	200	188	238	140	100	70	21.5
	100	DHT50-100	500	255	784	400	238	338	140	100	70	26
	150	DHT50-150	500	255	1176	600	288	438	140	100	70	31
	200	DHT50-200	500	255	1563	800	338	538	140	100	70	35
	300	DHT50-300	500	255	2352	1200	438	738	140	100	70	44
100	50	DHT100-50	1000	490	770	377	216	266	180	140	100	42
	100	DHT100-100	1000	490	1540	754	266	366	180	140	100	49
	150	DHT100-150	1000	490	2310	1131	316	466	180	140	100	56
	200	DHT100-200	1000	490	3080	1508	366	566	180	140	100	63
	300	DHT100-300	1000	490	4620	2262	466	766	180	140	100	70
150	50	DHT150-50	1390	709	1005	512	224	274	210	160	112	44
	100	DHT150-100	1390	709	2010	1025	274	374	210	160	112	57
	150	DHT150-150	1390	709	3015	1537	324	474	210	160	112	70
	200	DHT150-200	1390	709	4020	2050	374	574	210	160	112	83
	300	DHT150-300	1390	709	6030	3075	474	774	210	160	112	109
200	100	DHT200-100	2000	875	3141	1374	296	396	250	200	150	109
	150	DHT200-150	2000	875	4712	2061	346	496	250	200	150	121
	200	DHT200-200	2000	875	6282	2748	396	596	250	200	150	132
	300	DHT200-300	2000	875	9423	4122	496	796	250	200	150	155
300	100	DHT300-100	3193	1537	4906	2363	327	427	315	250	180	180
	200	DHT300-200	3193	1537	9812	4726	427	627	315	250	180	220
	300	DHT300-300	3193	1537	14718	7089	527	827	315	250	180	260
400	100	DHT400-100	3919	1317	5723	1924	355	455	355	270	220	255
	200	DHT400-200	3919	1317	11446	3848	455	655	355	270	220	310
	300	DHT400-300	3919	1317	17169	5772	555	855	355	270	220	375
500	100	DHT500-100	5000	1948	8038	3133	375	475	395	320	250	326
	200	DHT500-200	5000	1948	16076	6266	475	675	395	320	250	394
	300	DHT500-300	5000	1948	24114	9399	575	875	395	320	250	462
600	100	DHT600-100	6300	2488	10174	4019	436	536	450	360	280	542
	200	DHT600-200	6300	2488	20348	8038	536	736	450	360	280	634
	300	DHT600-300	6300	2488	30522	12057	636	936	450	360	280	726
800	100	DHT800-100	8000	2880	12566	4522	477	577	550	400	320	796
	200	DHT800-200	8000	2880	25132	9044	577	777	550	400	320	944
	300	DHT800-300	8000	2880	37698	13566	677	977	550	400	320	1092

## Tube Installation Tools & Equipments



## Tube Facing / Beveling Machine



## Tube Removal Tools & Equipment



## Tube Cleaning Equipment



Nominal Size		Flange Size																	
		150			300			600			900			1500			2500		
Inches	Metric	No. of Bolts	Bolt dia inches	Bolt dia mm	No. of Bolts	Bolt dia inches	Bolt dia mm	No. of Bolts	Bolt dia inches	Bolt dia mm	No. of Bolts	Bolt dia inches	Bolt dia mm	No. of Bolts	Bolt dia inches	Bolt dia mm	No. of Bolts	Bolt dia inches	Bolt dia mm
1/2	15	4	1/2	14	4	1/2	14	4	1/2	14	4	3/4	20	4	3/4	20	4	3/4	20
3/4	20	4	1/2	14	4	5/8	16	4	5/8	16	4	3/4	20	4	3/4	20	4	3/4	20
1	25	4	1/2	14	4	5/8	16	4	5/8	16	4	7/8	24	4	7/8	24	4	7/8	24
1.1/4	32	4	1/2	14	4	5/8	16	4	5/8	16	4	7/8	24	4	7/8	24	4	1	27
1.1/2	40	4	1/2	14	4	3/4	20	4	3/4	20	4	1	27	4	1	27	4	1.1/8	30
2	50	4	5/8	16	8	5/8	16	8	5/8	20	8	7/8	24	8	7/8	24	8	1	27
2.1/2	65	4	5/8	16	8	3/4	20	8	3/4	20	8	1	27	8	1	27	8	1.1/8	30
3	80	4	5/8	16	8	3/4	20	8	3/4	20	8	7/8	24	8	7/8	24	8	1.1/8	30
3.1/2	90	8	5/8	20	8	3/4	20	8	7/8	22	8	-	-	-	-	-	-	-	-
4	100	8	5/8	20	8	3/4	20	8	7/8	24	8	1.1/8	30	8	1.1/8	30	8	1.1/4	33
5	125	8	3/4	20	6	3/4	20	8	1	27	8	1.1/4	33	8	1.1/2	39	8	1.3/4	45
6	150	8	3/4	20	12	3/4	24	12	1	27	12	1.1/8	30	12	1.3/8	36	8	2	52
8	200	8	3/4	24	12	7/8	27	12	1.1/8	30	12	1.3/8	36	12	1.5/8	42	12	2	52
10	250	12	7/8	24	16	1	30	16	1.1/4	33	16	1.3/8	35	12	1.7/8	48	12	2.1/2	64
12	300	12	7/8	27	16	1.1/8	30	20	1.1/4	33	20	1.3/8	36	12	2	52	12	2.3/4	70
14	350	12	1	27	20	1.1/8	33	20	1.3/8	36	20	1.1/2	39	16	2.1/4	56			
16	400	16	1	30	20	1.1/4	33	20	1.1/2	39	20	1.5/8	42	16	2.1/2	54			
18	450	16	1.1/8	30	24	1.1/4	33	20	1.5/8	42	20	1.7/8	48	16	2.3/4	70			
20	500	20	1.1/8	33	24	1.1/4	33	24	1.5/8	42	20	2	52	16	3	76			
24	600	20	1.1/4	33	24	1.1/2	42	24	1.7/8	48	20	2.1/2	64	16	3.1/2	90			
26	650	24	1.1/2	33	28	1.1/4	42	24	1.3/4	48	20	2.3/4	70						
28	700	28	1.1/2	33	28	1.1/2	45	28	2	52	16	3	76						
30	750	28	1.1/2	33	28	1.3/4	40	28	2	52	20	3	76						
32	800	28	1.1/2	39	28	1.1/4	48	28	2.1/2	56	20	3.1/2	85						
34	850	32	1.1/2	39	28	1.1/2	48	28	2.1/2	56	20	3.1/2	90						
36	900	32	1.1/2	39	32	2	52	28	2.1/2	64	20	3.1/2	90						

# TORQUE SPECIFICATIONS



Bolt Size	A/F	Bolt Grade: 8.8				Bolt Grade: 10.9				Bolt Grade: 12.9				Bolt Size	A/F	Bolt Grade: B7/B16			
		Torque Values (Nm)			Tension (KN)	Torque Values (Nm)			Tension (KN)	Torque Values (Nm)			Tension (KN)			Torque Values (Nm)			Tension (KN)
		$\mu=0.10$	$\mu=0.15$	$\mu=0.2$		$\mu=0.10$	$\mu=0.15$	$\mu=0.2$		$\mu=0.10$	$\mu=0.15$	$\mu=0.2$				$\mu=0.10$	$\mu=0.15$	$\mu=0.2$	
M16	24	121	165	208	54	171	232	292	76	205	278	351	91	5/8"	1.1/16"	126	171	215	57
M18	27	165	224	283	66	233	316	399	92	279	379	478	111	-	-	-	-	-	-
M20	30	237	322	406	85	333	452	571	119	400	543	685	143	3/4"	1.1/4"	226	306	387	85
M22	32	327	443	560	106	459	623	787	149	551	748	945	179	7/8"	1.7/16"	366	496	627	117
M24	36	409	556	702	122	576	781	987	171	691	938	1184	206	-	-	-	-	-	-
M27	41	608	828	1043	161	855	1161	1467	226	1027	1393	1760	272	1"	1.5/8"	549	745	941	154
M30	46	820	1113	1406	195	1154	1566	1978	275	1384	1879	2373	330	1.1/8"	1.13/16"	816	1107	1398	204
M33	50	1128	1531	1933	244	1586	2152	2719	343	1903	2583	3263	412	1.1/4"	2"	1157	1570	1983	260
M36	55	1442	1957	2472	286	2028	2752	3476	402	2433	3302	4171	483	1.3/8"	2.3/16"	1582	2147	2712	324
M39	60	1881	2553	3225	345	2646	3590	4535	485	3175	4308	5442	581	1.1/2"	2.3/8"	2100	2850	3600	394
M42	65	2317	3145	2973	394	3259	4423	5587	554	3911	5307	6704	665	1.5/8"	2.9/16"	2720	3692	4663	471
M45	70	2912	3952	4992	462	4095	5558	7021	650	4914	6670	8425	780	1.3/4"	2.3/4"	3452	4685	5917	555
M48	75	3490	4737	5984	519	4909	6662	8415	730	5890	7994	10097	877	1.7/8"	2.15/16"	4304	5841	7378	645
M52	80	4545	6169	7792	624	6392	8675	10958	878	7670	10410	13149	1054	2"	3.1/8"	5285	7173	9060	743
M56	85	5642	7658	9673	720	7935	10768	13602	1012	9522	12922	16323	1214	2.1/4"	3.1/2"	7674	10414	13155	959
M60	90	7076	9603	12130	842	9951	13504	17058	1185	11941	16205	20470	1422	-	-	-	-	-	-
M64	95	8535	11583	14631	953	12002	16289	20575	1340	14403	19547	24690	1607	2.1/2"	3.7/8"	10691	14509	18327	1203
M68	100	10405	14121	17838	1093	14632	19858	25084	1537	17559	23830	30101	1844	2.3/4"	4.1/4"	13038	17694	22350	1333
M72	105	12530	17005	21480	1243	17620	23913	30206	1748	-	-	-	-	-	-	-	-	-	-
M76	110	14926	20256	25587	1403	20989	28485	35981	1973	-	-	-	-	-	-	-	-	-	-
M80	115	17608	30185	1572	1572	-	-	-	-	-	-	-	-	3"	4.5/8"	17104	23213	29321	1603
M85	120	21390	29029	36668	1797	-	-	-	-	-	-	-	-	-	-	-	-	-	-
M90	130	25676	34847	44017	2038	-	-	-	-	-	-	-	-	3.1/4"	5"	21938	29774	37609	1898
M95	135	30500	41393	52286	2293	-	-	-	-	-	-	-	-	3.1/2"	5.3/8"	27607	37467	47326	2218
M100	145	35893	48712	61531	2564	-	-	-	-	-	-	-	-	3.3/4"	5.3/4"	34176	46382	58588	2563
M105	150	41886	56846	71805	2849	-	-	-	-	-	-	-	-	4"	6.1/8"	41712	56610	71507	2933
M110	155	48511	65837	83162	3150	-	-	-	-	-	-	-	-	-	-	-	-	-	-

$\mu=0.10$  - Lubricated Bolts  
 $\mu=0.15$  - Semi Lubricated Bolts  
 $\mu=0.2$  - Dry Bolts

Newton - Meter Nm to Foot-Pounds lbf. ft. (1Nm = 0.738 lbf. ft.)  
 Kilogram - Force Meter to Newton - Meter (1 Kgm = 9.80 Nm)



# TRITORC

B O L T O N T R U S T

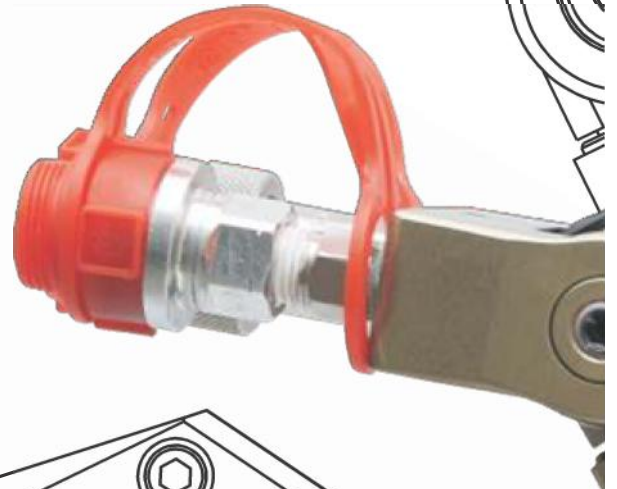
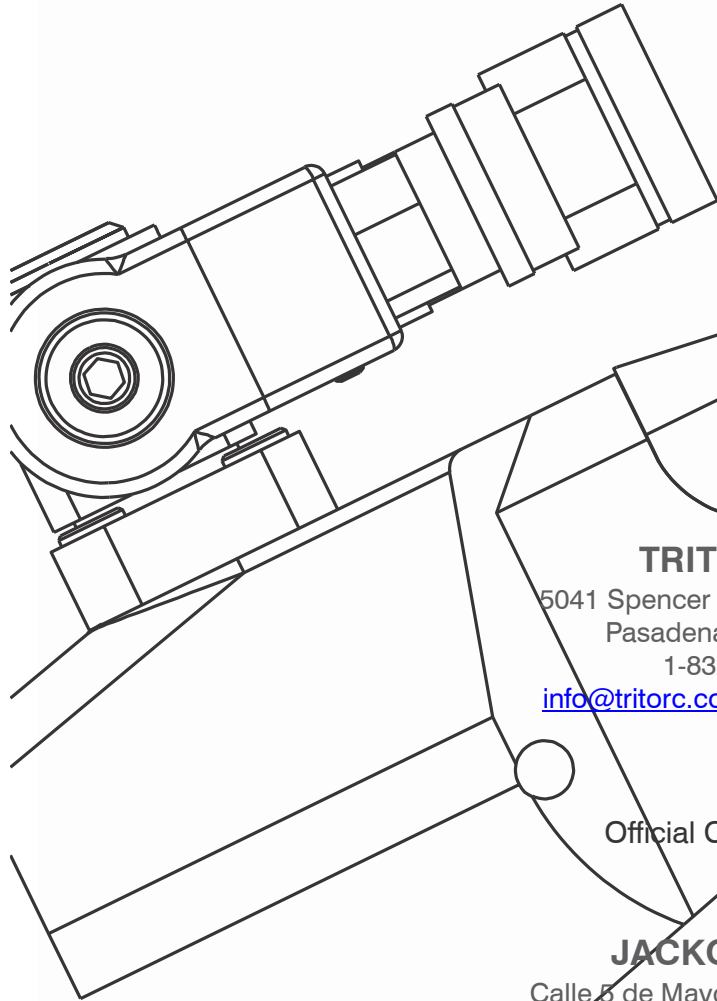

## TRITORC INC,

5041 Spencer Highway Suite #302,  
Pasadena, Texas - 77502  
1-832-831-4342

[info@tritorc.com](mailto:info@tritorc.com) | [www.tritorc.com](http://www.tritorc.com)

Official Channel Partner

## JACKO SA DE CV

Calle 5 de Mayo. No. 3. Fracc. H. de Nacoza.  
C.P. 24158 Cd. Del Carmen, Campeche.  
938 112 3727

[contacto@jacko-offshore.com](mailto:contacto@jacko-offshore.com) | [www.jacko-offshore.com](http://www.jacko-offshore.com)